



Service Bulletin

no. 77-1 (revised)

Date: OCTOBER 1977

Subject: PRE-DELIVERY

Serial nos: 7854, 7864

Models: MX-3 175-250

UNCRATING

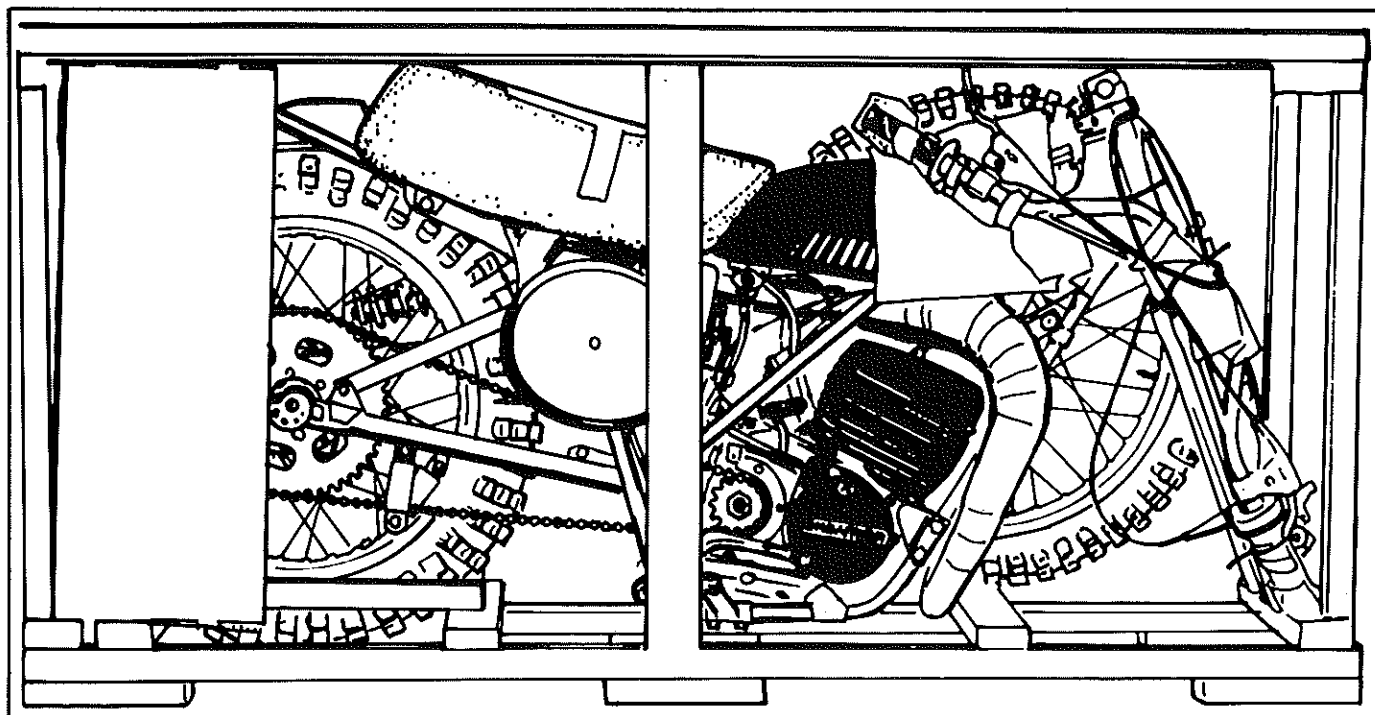

◆ **WARNING:** Strapping is under pressure, therefore, care must be taken while cutting.

Remove staples holding top cover and remove cover.

Remove crate ends and crate sides.

▼ **CAUTION:** Care should be taken during panel removal to prevent vehicle from being scratched.

Remove the vehicle from the wooden base, and mount it on a box or a stand.

○ **NOTE:** The information contained in this bulletin does not constitute a warranty authorization.

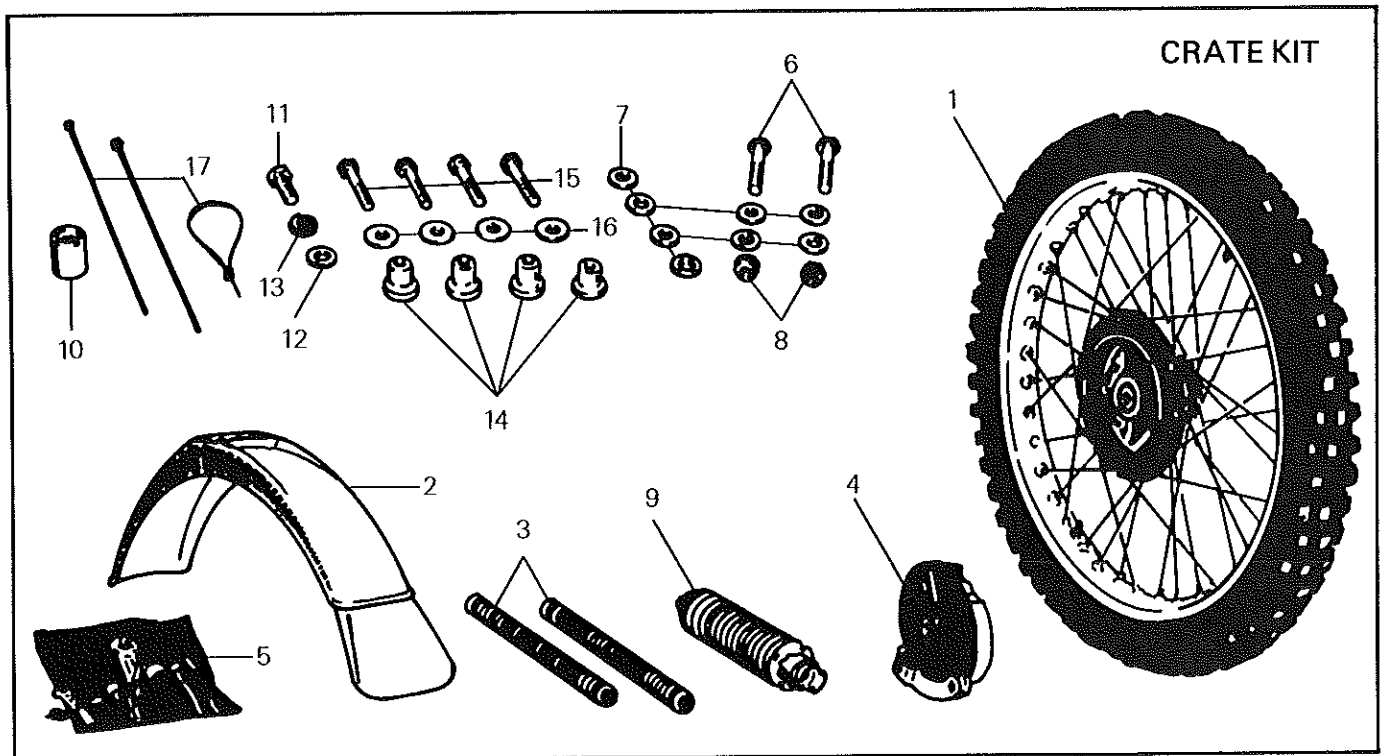

- | | |
|--|--|
| <p>1. Front wheel 2. Front fender ass'y 3. Spring front fork (2) 4. Backing plate front ass'y 5. Tool kit 6. Shock absorber retaining bolt M8 x 1.25 x 40 (2) 7. Flat washer 8 mm x 17 x 2 (8) 8. Elastic stop nut M8 x 1.25 (2) 9. Shock absorber</p> | <p>10. Front wheel spacer 11. Front brake torque arm screw M8 x 20 12. Flat washer M8 x 17 x 2 13. Lockwasher 3/16" 14. Front fender spacer (4) 15. Front fender screw M6 x 1.00 x 35 (4) 16. Flat washer 6 mm x 20 x 2 (4) 17. Tie wrap (3)</p> |
|--|--|

ASSEMBLY INSTRUCTIONS

HANDLEBAR

Install the handlebar in the desired position and torque the retaining screws to 1.4-1.6 kg-m (10-12 ft-lbs).

- NOTE: Use the tie wraps to fasten all electrical wires to the handlebar.

FRONT FENDER

Install the front fender with the spacers and washers positioned as illustrated.

Torque the retaining screws to .4-.5 kg-m (3-4 ft-lbs).

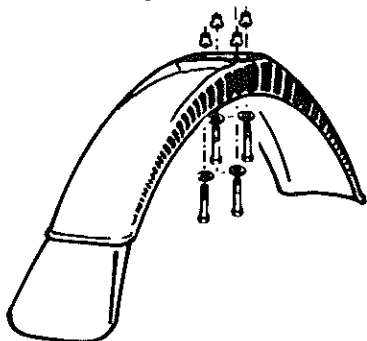

- NOTE: On the 250 model, 4 large spacers and 4 screws M6 x 1.00 x 25 are used.

FORK SPRINGS

Loosen the top crown clamp screws and remove the fork spring retaining caps. Insert the fork springs.

Reinstall the fork spring retaining caps and torque to 4.1-5.5 kg-m (30-40 ft-lbs).

Torque the top crown clamp screws to .8-1.1 kg-m (6-8 ft-lbs) on the 175 model and to 4.8-5.5 kg-m (35-40 ft-lbs) on the 250 model.

- NOTE: The forks are pre-filled with SAE 10W fork oil.
175 model: 220 ml (7.7 fl. oz)
250 model: 250 ml (8.8 fl. oz)

FRONT WHEEL INSTALLATION

175 model

Remove the axle nut, loosen the axle pinch bolts and remove the axle.

◆ **WARNING:** Make sure there are no fasteners lodged inside the front backing plate assembly, it may cause the front wheel to jam, stop or skid.

Position the spacer on the magneto side, and the brake plate on the other.

Position the wheel and insert the axle from the magneto side, slightly tighten axle nut making sure the left fork leg boss is in the backing plate channel.

Install the front brake cable.

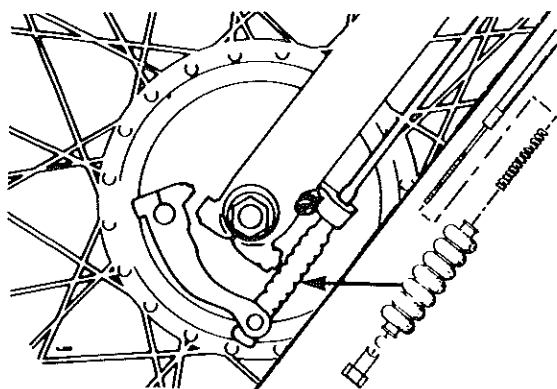

Spin front wheel in forward rotation, apply brake and while holding brake on. Torque axle nut to 3.4-8 kg-m (25-60 ft-lbs).

○ **NOTE:** This is important, it centers the brake shoes.

▼ **CAUTION:** To ensure correct fork action, briskly compress forks (with front brake applied) to align fork legs before tightening axle pinch bolts.

Retorque axle pinch bolt to 2-2.8 kg-m (15-20 ft-lbs).

250 model

Remove the axle nut, loosen the axle pinch bolts and remove the axle.

Loosen the front brake torque arm upper retaining bolts.

◆ **WARNING:** Make sure there are no fasteners lodged inside the front backing plate assembly, it may cause the front wheel to jam, stop or skid.

Position the spacer on the clutch side, and the brake plate on the other.

Position the wheel and insert the axle from the clutch side. Slightly tighten the axle nut. Secure the torque arm to the backing plate and torque the retaining bolts to 4.1-5.5 kg-m (30-40 ft-lbs). Install and route the front brake cable. As illustrated.

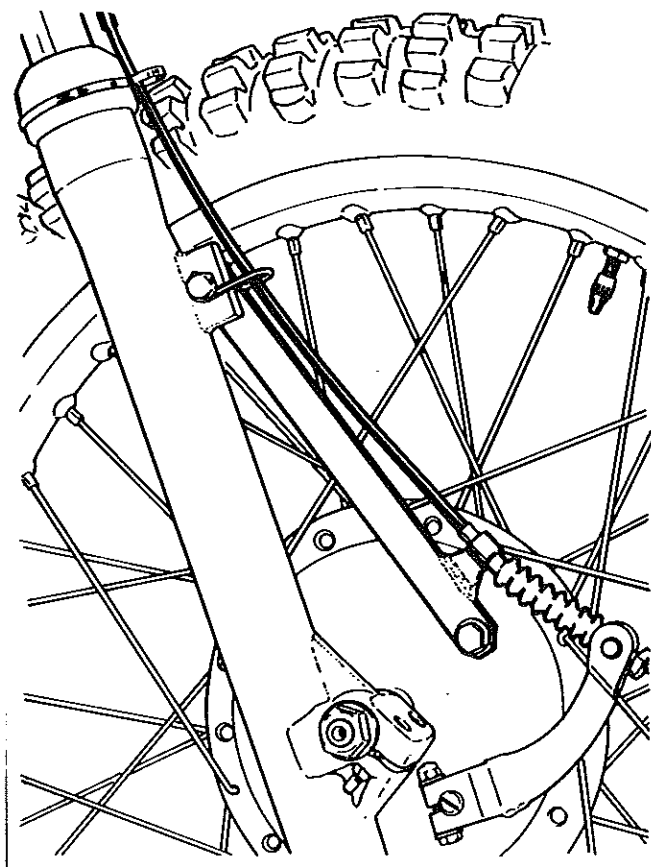

Spin front wheel in forward rotation, apply brake and while holding brake on, torque the axle nut to 3.4-8 kg-m (25-60 ft-lbs).

○ **NOTE:** This is important, it centers the brake shoes.

▼ **CAUTION:** To ensure correct fork action, briskly compress forks (with front brake applied) to align fork legs before tightening axle pinch bolts.

Retorque axle pinch bolts to .8-1.1 kg-m (6-8 ft-lbs).

REAR SHOCKS

Remove both left and right number plates.

Remove the rear brace support (used for transport).

Prior to assembly, install two flat washers 8 mm x 17 x 2 on the upper shock absorber retaining bolt (brake side). Raise the rear end slightly then mount the brake side shock on the swing arm, making sure to use two flat washers 8 mm x 17 x 2.

Install the sprocket side shock in the same manner.

Torque the shock absorber retaining bolts to 2.-2.8 kg-m (15-20 ft-lbs).

Reinstall both number plates.

CLEANING

Clean the motorcycle thoroughly with a cotton cloth to remove the anti-rust spray.

PRE-DELIVERY INSPECTION

AIR FILTER SERVICE

Remove the seat by slackening the two (2) rear retaining screws.

Remove the filter from its plastic bag. Separate the foam from the screen.

Pour the specially formulated filter compound onto the element and work it well into the foam until the filter is completely saturated. Fit the element onto the screen.

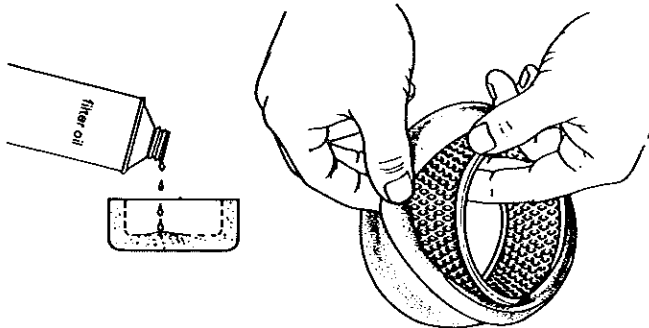

Remove the plastic nut and air filter pan. Apply a heavy coat of grease around the threaded portion of the air box. Re-install the filter pan and firmly tighten the plastic nut. Generously grease the bottom edge of the foam and install the filter.

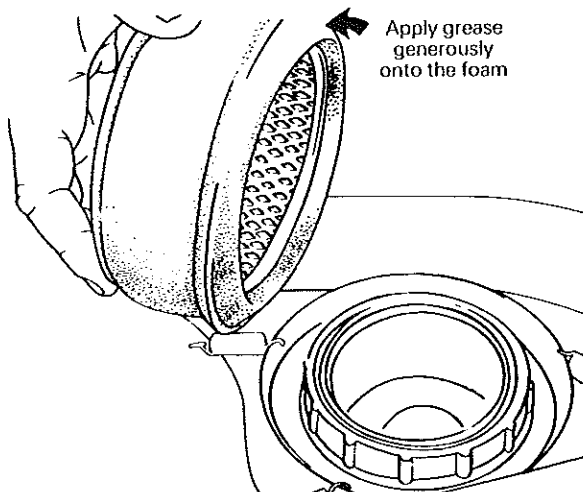
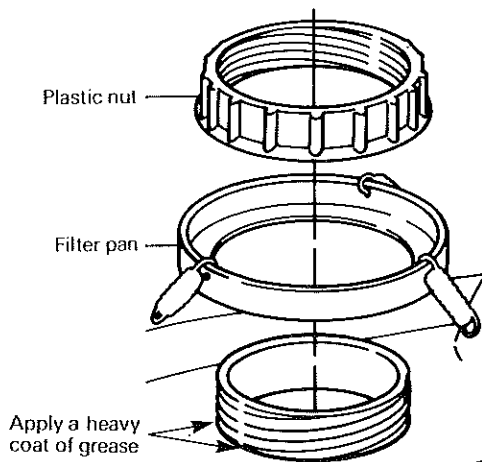

○ NOTE: Be sure the filter edge is tucked into the metal pan.

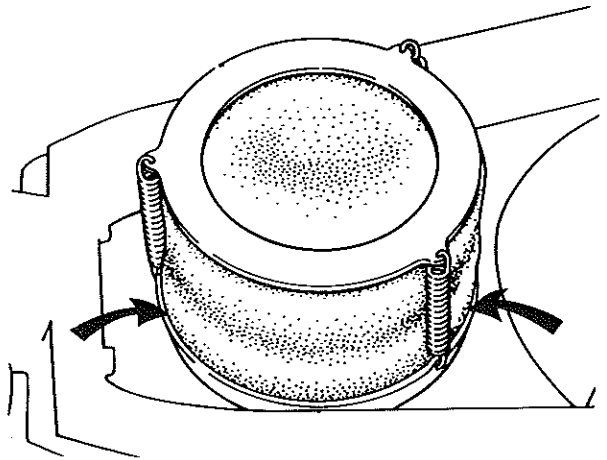

▼ CAUTION: A dry filter will cause extreme piston and cylinder damage that may not be covered by warranty.

THROTTLE CABLE SYNCHRONIZATION

Using the cable adjuster located on the throttle slide chamber cover, set cable slack to 1.6 mm ($\frac{1}{16}$ ").

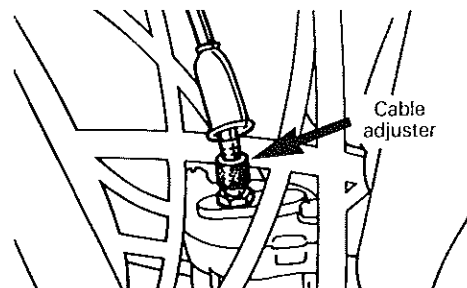

On the MX-3 models, the oil injection pump is preset to deliver a constant amount of oil at any given R.P.M. and does not require any adjustment.

◆ WARNING: Before starting engine, carburetor slide must be free to snap back to idle position. Make sure the rubber grip does not rub on the throttle body.

CLUTCH ADJUSTMENT

Prior to clutch adjustment, the clutch cable access plug must be screwed in, and the clutch lever operated a couple of times to seat the cable in place.

Loosen the clutch cable adjuster (at handlebar) to provide maximum slack. Remove the clutch adjustment access plug and loosen the 4 mm set screw. Turn the 8 mm clutch adjusting screw in and out to locate the point of contact with the release bearing, then turn the screw ¼ turn out (counter-clockwise).

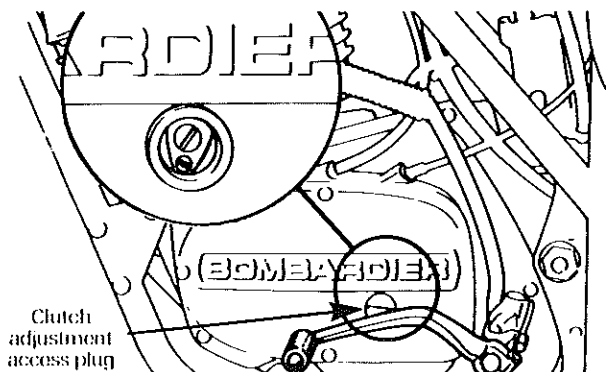

Carefully tighten the 4 mm set screw to lock the adjustment. Replace the access plug.

Adjust the cable adjuster to provide 1.6 mm (1/16") slack, between clutch lever and housing.

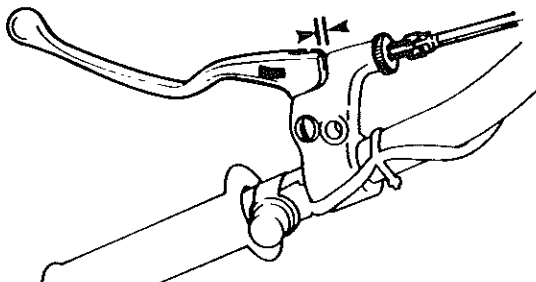

DRIVE CHAIN ADJUSTMENT

Loosen the rear axle nut and move each adjuster plate equally to tighten or loosen chain as required.

NOTE: Alignment marks on adjuster plate must be at the same position on each side of the wheel.

Starting just in front of the forward chain guide bracket, the drive chain (top run portion) at 38 mm (1½ ") distance from the swing arm. (Measured at the chain's tightest point).

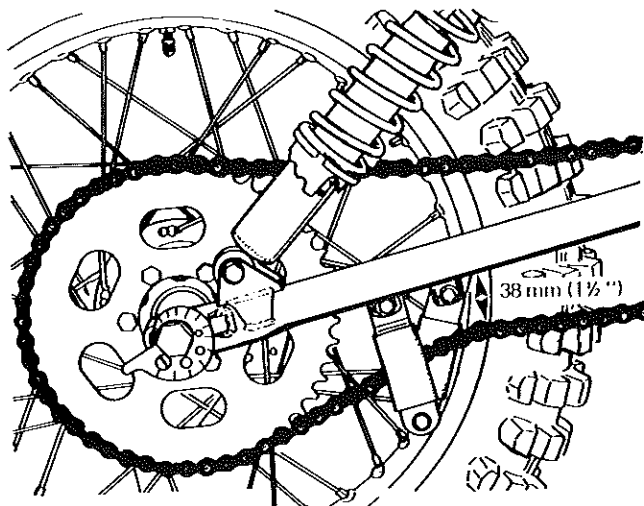

NOTE: Master link clip must be installed with its closed end facing the direction of travel.

TRANSMISSION OIL LEVEL

With the motorcycle in a vertical position, remove the transmission oil level plug and check the oil level.

Oil level should be to the level plug. Add oil through filler / vent plug if necessary. (SAE 80, gear oil).

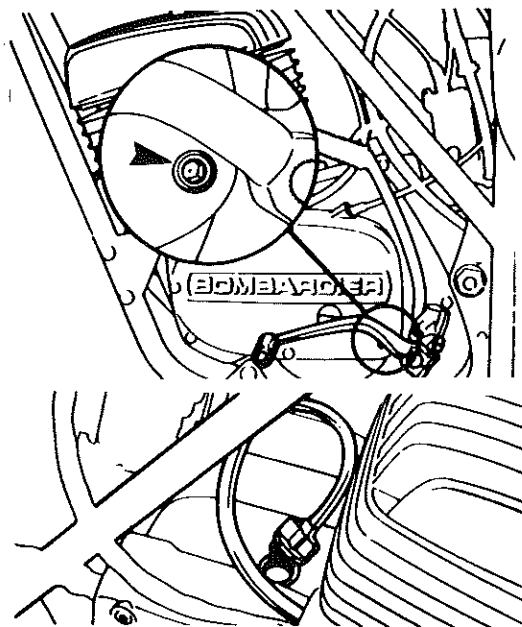

BRAKE ADJUSTMENT

Front

Completely loosen the brake cable adjuster (at handlebar), then using the adjuster located at the brake plate, adjust the cable to provide 25 mm (1") of free lever travel at handlebar.

NOTE: Use adjuster at handlebar for final adjustment.

Rear

Turn the cable adjusting nut until the brake pedal free travel is 25 mm (1").

NOTE: The brake pedal height can be adjusted as desired by moving the stopper.

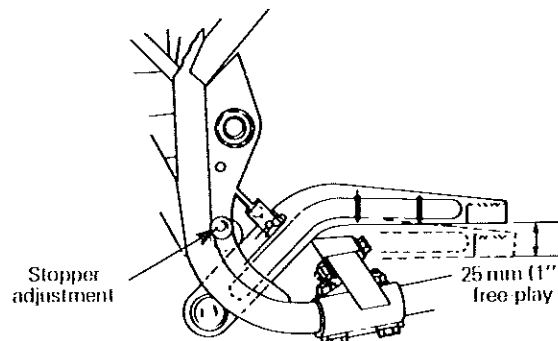

CARBURETOR ADJUSTMENT

Idle speed and mixture adjustment

With the motorcycle held in a vertical position, gently turn air mixture adjusting screw in until it stops, then back it out to $1\frac{1}{4}$ turn.

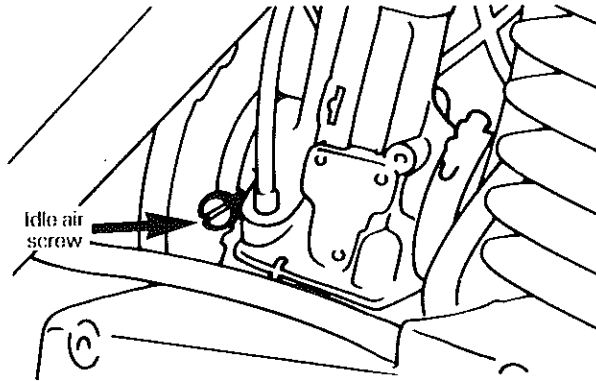

Start the engine and allow it to warm.

Adjust idle speed screw in or out for desired idle speed (Approximately 1,000 R.P.M.)

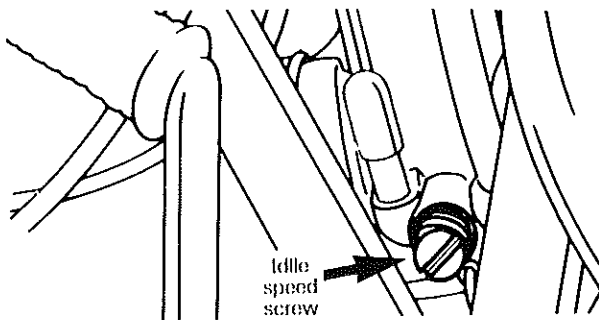

○ NOTE: The air mixture screw can be turned in or out (within $\frac{1}{4}$ turn of basic setting) to achieve smoothest idle possible. Re-adjust idle speed if necessary.

ENGINE TIMING

Timing mark verification

Disconnect the spark plug wire and remove the spark plug.

Remove the inspection plug on the magneto cover.

Install and adjust the top dead center gauge.

Rotate the rear wheel counter-clockwise until the piston is at $1.2 \text{ mm} \pm 0.2$ ($.047'' \pm .007$) before top dead center.

Check through the inspection hole, the flywheel / rotor and the magneto cover marks must align perfectly.

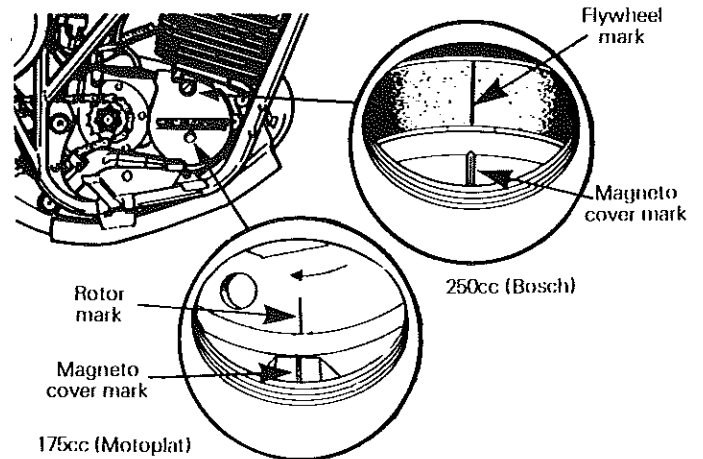

If the marks do not align, scribe a new mark on the magneto cover in line with the flywheel / rotor mark at $1.2 \text{ mm} \pm .2$ ($.047'' \pm .007$) before top dead center.

▼ CAUTION: The timing mark verification cannot be used as a timing procedure therefore always check the timing (using a stroboscopic timing light at 9000 R.P.M.) after the marks have been aligned.

Re-install the spark plug and connect the high tension spark plug wire.

Timing light procedure

Remove the timing inspection plug, and connect the timing light pick-up to the high tension wire.

Start the engine and allow it to warm.

◆ WARNING: To prevent powerful electric shock, do not touch the high tension wire while the engine is running.

Point the timing light beam straight into the inspection hole and briefly rev the engine to 9000 R.P.M. The timing marks on the magneto cover and on the flywheel / rotor should align. Stop the engine.

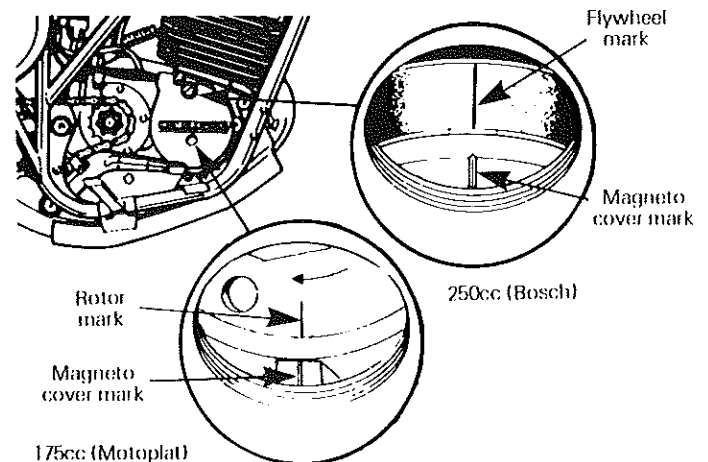

CAUTION: Timing marks must be checked with a dial indicator for perfect accuracy.

If the timing marks do not align, remove the magneto cover, slacken the stator plate retaining screws and move the stator plate in the advance or retard direction to correct the misalignment.

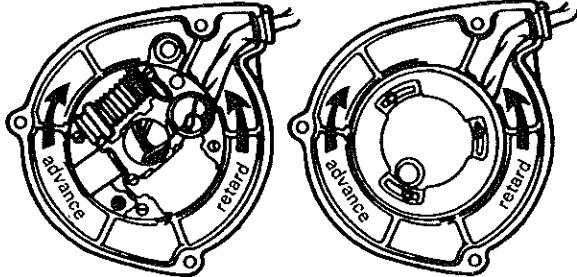

250cc (Bosch)

175cc (Motoplatt)

NOTE: Only stroboscopic timing lights utilizing a capacitor or inductive pick-up can be used to indicate correct spark setting without disturbing the electronic equilibrium of the ignition circuit.

Examples of suitable lights:

Sun PTL 45
Snap-on MT215B
Bosch EFAW 169A

TIRE PRESSURE

Check and adjust as required.

The recommended pressure is:

Terrain conditions

| | |
|-------------------------|---|
| Dry, rocky terrain | Front: 84 kPa (12 P.S.I.) Rear: 84 kPa (12 P.S.I.) |
| Soft, wet muddy terrain | Front: 70 kPa (10 P.S.I.) Rear: 70 kPa (10 P.S.I.) |

TEST RIDE MOTORCYCLE

Fill the oil reservoir with injection oil, and the gas tank with premium gasoline only.

Start the motorcycle and test ride briefly for abnormal noises or faulty operation. Run through all the gears, checking for performance, braking and handling, etc... Note the suspension action and throttle response.

Clean the vehicle thoroughly. Explain the operator manual to the customer.

NOTE: Make sure the customer is well aware of the engine break-in procedure.

FIRST FIVE HOURS

- Do not run the engine at excessive R.P.M.
- Shift gears frequently to keep the engine running freely at a moderate R.P.M. range without subjecting it to extreme loads (lugging, overrevving, etc.).
- Make any necessary corrections or adjustments of controls, spokes, drive chain, etc.
- Check for loose nuts, bolts and fasteners. Tighten them if necessary.

1977 MX-3 PRE-DELIVERY TECHNICAL DATA

| | |
|--|---|
| Throttle & injector pump synchronization | 1.6 mm ($\frac{1}{16}$ ") free-play at carburetor top. Marks must align on injection pump. |
| Clutch adjustment | At engine: $\frac{1}{4}$ turn counter-clockwise before point of contact. At handlebar: 1.6 mm ($\frac{1}{16}$ ") free-play between clutch lever and housing. |
| Chain adjustment | Top run of the chain at 38 mm ($1\frac{1}{2}$ ") distance from the swing arm. |
| Brake adjustment | 25 mm (1") of free-play at end of lever or pedal. |
| Transmission oil level | Up to level plug (SAE 80, gear oil). |
| Ignition timing at 9000 R.P.M. | Timing marks of magneto cover and flywheel / rotor must align. |
| Basic timing | 1.2 mm (.047") before top dead center. |
| Tire pressure | Dry, rocky terrain Front: 84 kPa (12 P.S.I.) Rear: 84 kPa (12 P.S.I.) Soft, wet muddy terrain Front: 70 kPa (10 P.S.I.) Rear: 70 kPa (10 P.S.I.) |

CARBURETOR SPECIFICATIONS

| | |
|----------------------------|-----------------------------------|
| Vehicle model | MX-3 175-250cc (No's 7854 & 7864) |
| Carburetor | 1-32-104 |
| Std. main jet (production) | 155 |
| Needle jet | 270 |
| Idle jet | 40 |
| Needle identification | 4 rings |
| Needle setting | 3rd groove from top |
| Slide | No. 1 |
| Air screw | $1\frac{1}{4}$ turn out |
| Float level | 25 mm (1") |
| Idle speed | 1000 R.P.M. |



Service Bulletin

no. 77-1 (revised)

Date: OCTOBER 1977

Subject: PRE-DELIVERY

Serial nos: 7854, 7864

Models: MX-3 175-250

UNCRATING

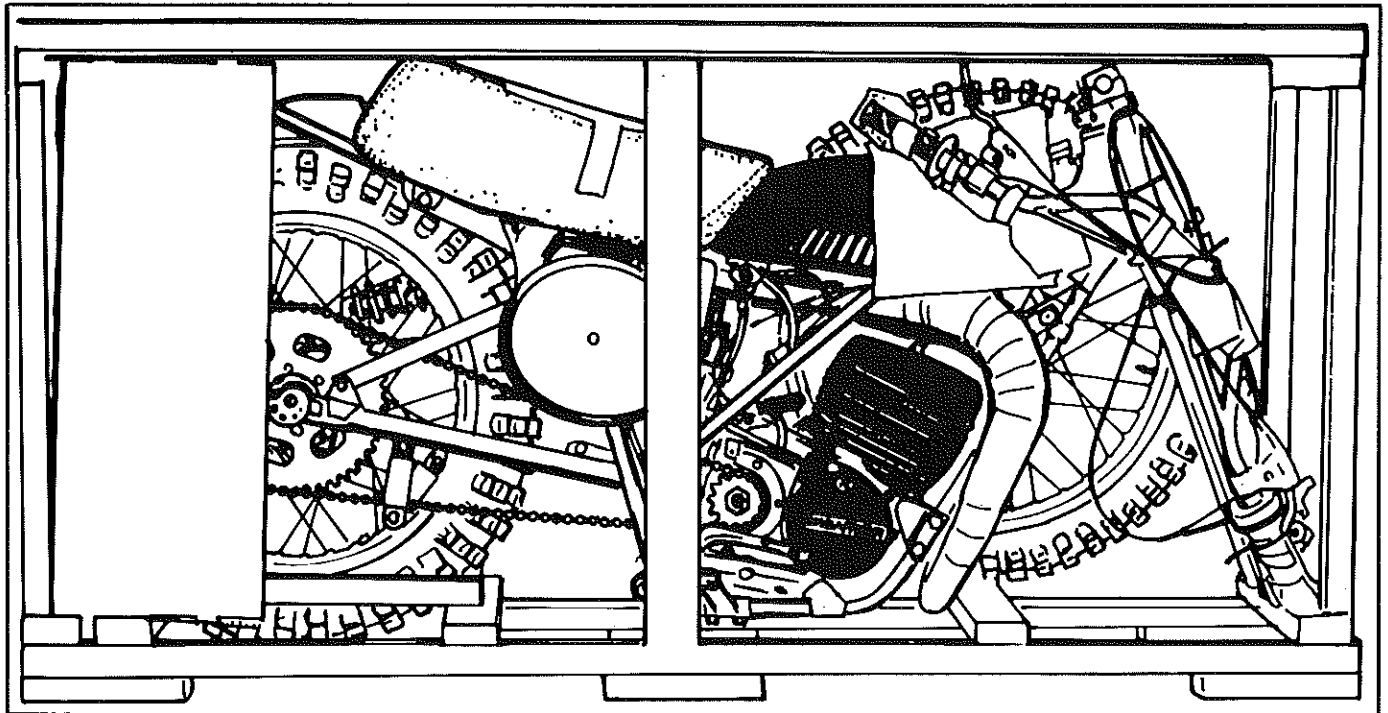

◆ **WARNING:** Strapping is under pressure, therefore, care must be taken while cutting.

Remove staples holding top cover and remove cover.

Remove crate ends and crate sides.

▼ **CAUTION:** Care should be taken during panel removal to prevent vehicle from being scratched.

Remove the vehicle from the wooden base, and mount it on a box or a stand.



NOTE: The information contained in this bulletin does not constitute a warranty authorization.

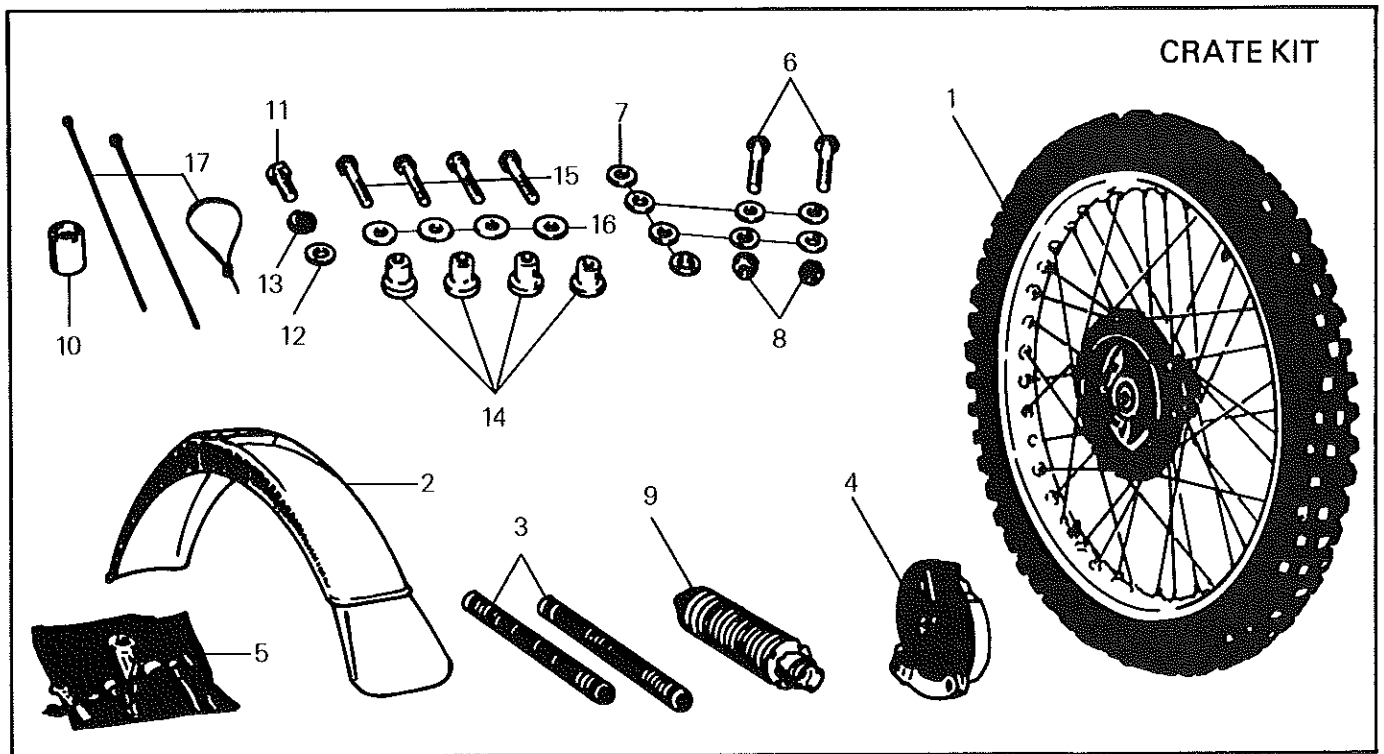

- 1. Front wheel
- 2. Front fender ass'y
- 3. Spring front fork (2)
- 4. Backing plate front ass'y
- 5. Tool kit
- 6. Shock absorber retaining bolt M8 x 1.25 x 40 (2)
- 7. Flat washer 8 mm x 17 x 2 (8)
- 8. Elastic stop nut M8 x 1.25 (2)
- 9. Shock absorber

- 10. Front wheel spacer
- 11. Front brake torque arm screw M8 x 20
- 12. Flat washer M8 x 17 x 2
- 13. Lockwasher 3/16"
- 14. Front fender spacer (4)
- 15. Front fender screw M6 x 1.00 x 35 (4)
- 16. Flat washer 6 mm x 20 x 2 (4)
- 17. Tie wrap (3)

ASSEMBLY INSTRUCTIONS

HANDLEBAR

Install the handlebar in the desired position and torque the retaining screws to 1.4-1.6 kg-m (10-12 ft-lbs).

- NOTE: Use the tie wraps to fasten all electrical wires to the handlebar.

FRONT FENDER

Install the front fender with the spacers and washers positioned as illustrated.

Torque the retaining screws to .4-.5 kg-m (3-4 ft-lbs).

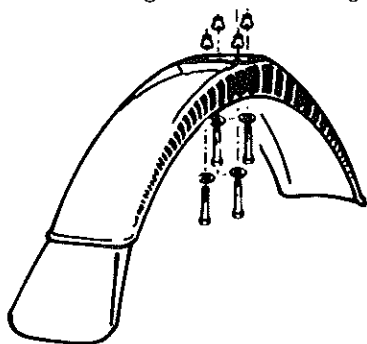

- NOTE: On the 250 model, 4 large spacers and 4 screws M6 x 1.00 x 25 are used.

FORK SPRINGS

Loosen the top crown clamp screws and remove the fork spring retaining caps. Insert the fork springs.

Reinstall the fork spring retaining caps and torque to 4.1-5.5 kg-m (30-40 ft-lbs).

Torque the top crown clamp screws to .8-1.1 kg-m (6-8 ft-lbs) on the 175 model and to 4.8-5.5 kg-m (35-40 ft-lbs) on the 250 model.

- NOTE: The forks are pre-filled with SAE 10W fork oil.
175 model: 220 ml (7.7 fl. oz)
250 model: 250 ml (8.8 fl. oz)

FRONT WHEEL INSTALLATION

175 model

Remove the axle nut, loosen the axle pinch bolts and remove the axle.

◆ **WARNING:** Make sure there are no fasteners lodged inside the front backing plate assembly, it may cause the front wheel to jam, stop or skid.

Position the spacer on the magneto side, and the brake plate on the other.

Position the wheel and insert the axle from the magneto side, slightly tighten axle nut making sure the left fork leg boss is in the backing plate channel.

Install the front brake cable.

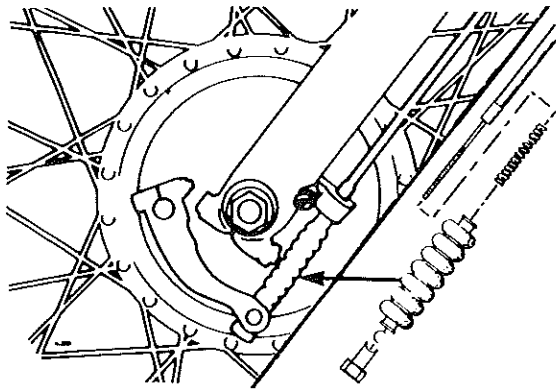

Spin front wheel in forward rotation, apply brake and while holding brake on. Torque axle nut to 3.4-8 kg-m (25-60 ft-lbs).

○ **NOTE:** This is important, it centers the brake shoes.

▼ **CAUTION:** To ensure correct fork action, briskly compress forks (with front brake applied) to align fork legs before tightening axle pinch bolts.

Retorque axle pinch bolt to 2-2.8 kg-m (15-20 ft-lbs).

250 model

Remove the axle nut, loosen the axle pinch bolts and remove the axle.

Loosen the front brake torque arm upper retaining bolts.

◆ **WARNING:** Make sure there are no fasteners lodged inside the front backing plate assembly, it may cause the front wheel to jam, stop or skid.

Position the spacer on the clutch side, and the brake plate on the other.

Position the wheel and insert the axle from the clutch side. Slightly tighten the axle nut. Secure the torque arm to the backing plate and torque the retaining bolts to 4.1-5.5 kg-m (30-40 ft-lbs). Install and route the front brake cable. As illustrated.

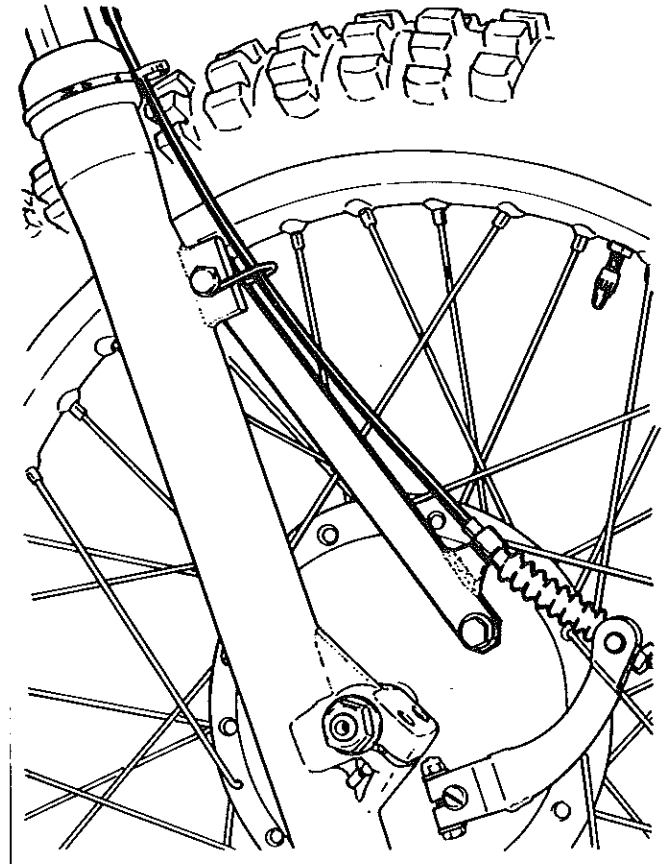

Spin front wheel in forward rotation, apply brake and while holding brake on, torque the axle nut to 3.4-8 kg-m (25-60 ft-lbs).

○ **NOTE:** This is important, it centers the brake shoes.

▼ **CAUTION:** To ensure correct fork action, briskly compress forks (with front brake applied) to align fork legs before tightening axle pinch bolts.

Retorque axle pinch bolts to .8-1.1 kg-m (6-8 ft-lbs).

REAR SHOCKS

Remove both left and right number plates.

Remove the rear brace support (used for transport).

Prior to assembly, install two flat washers 8 mm x 17 x 2 on the upper shock absorber retaining bolt (brake side). Raise the rear end slightly then mount the brake side shock on the swing arm, making sure to use two flat washers 8 mm x 17 x 2.

Install the sprocket side shock in the same manner.

Torque the shock absorber retaining bolts to 2.-2.8 kg-m (15-20 ft-lbs).

Reinstall both number plates.

CLEANING

Clean the motorcycle thoroughly with a cotton cloth to remove the anti-rust spray.

PRE-DELIVERY INSPECTION

AIR FILTER SERVICE

Remove the seat by slackening the two (2) rear retaining screws.

Remove the filter from its plastic bag. Separate the foam from the screen.

Pour the specially formulated filter compound onto the element and work it well into the foam until the filter is completely saturated. Fit the element onto the screen.

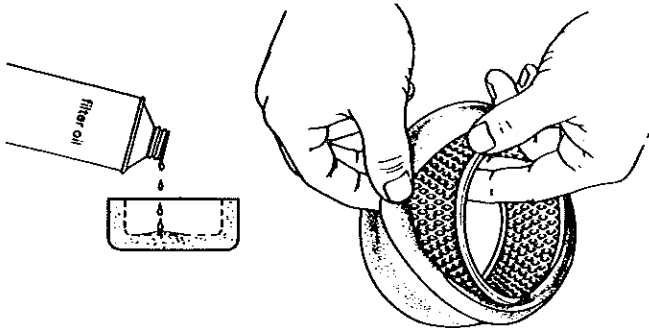

Remove the plastic nut and air filter pan. Apply a heavy coat of grease around the threaded portion of the air box. Re-install the filter pan and firmly tighten the plastic nut. Generously grease the bottom edge of the foam and install the filter.

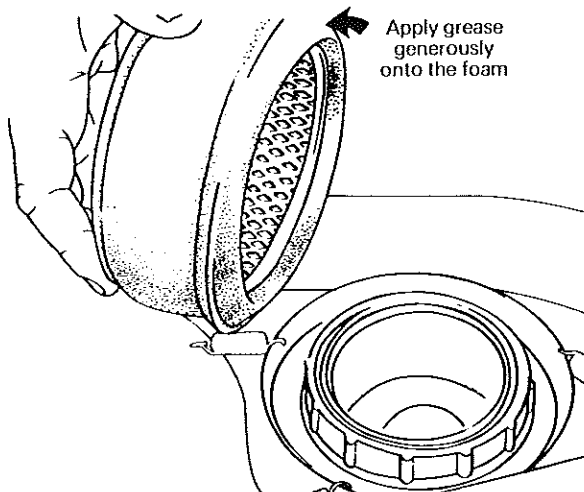
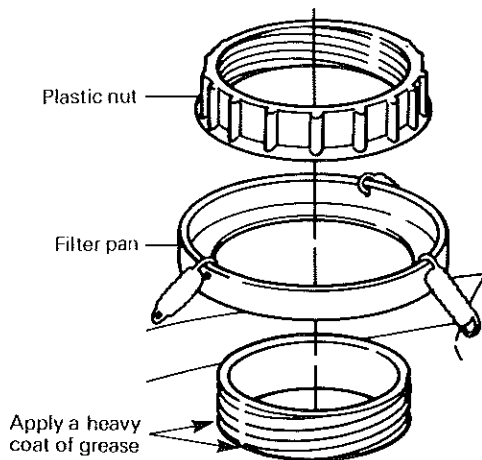

○ NOTE: Be sure the filter edge is tucked into the metal pan.

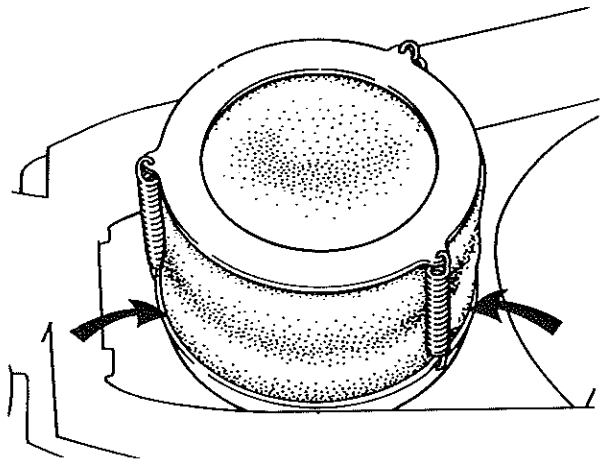

▼ CAUTION: A dry filter will cause extreme piston and cylinder damage that may not be covered by warranty.

THROTTLE CABLE SYNCHRONIZATION

Using the cable adjuster located on the throttle slide chamber cover, set cable slack to 1.6 mm ($\frac{1}{16}$ ").

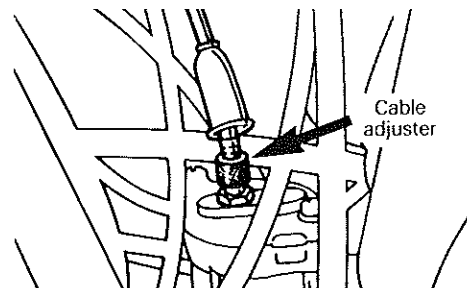

On the MX-3 models, the oil injection pump is preset to deliver a constant amount of oil at any given R.P.M. and does not require any adjustment.

◆ WARNING: Before starting engine, carburetor slide must be free to snap back to idle position. Make sure the rubber grip does not rub on the throttle body.

CLUTCH ADJUSTMENT

Prior to clutch adjustment, the clutch cable access plug must be screwed in, and the clutch lever operated a couple of times to seat the cable in place.

Loosen the clutch cable adjuster (at handlebar) to provide maximum slack. Remove the clutch adjustment access plug and loosen the 4 mm set screw. Turn the 8 mm clutch adjusting screw in and out to locate the point of contact with the release bearing, then turn the screw ¼ turn out (counter-clockwise).

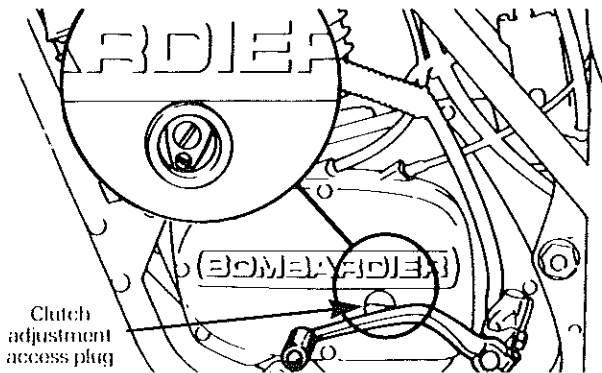

Carefully tighten the 4 mm set screw to lock the adjustment. Replace the access plug.

Adjust the cable adjuster to provide 1.6 mm (1/16") slack, between clutch lever and housing.

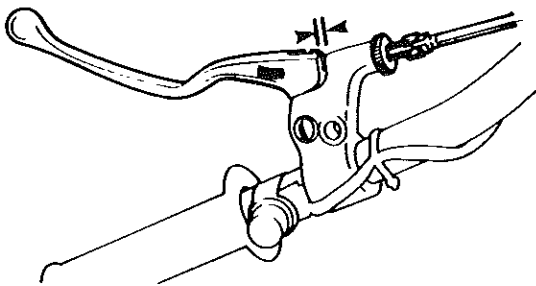

DRIVE CHAIN ADJUSTMENT

Loosen the rear axle nut and move each adjuster plate equally to tighten or loosen chain as required.

NOTE: Alignment marks on adjuster plate must be at the same position on each side of the wheel.

Starting just in front of the forward chain guide bracket, the drive chain (top run portion) at 38 mm (1½") distance from the swing arm. (Measured at the chain's tightest point).

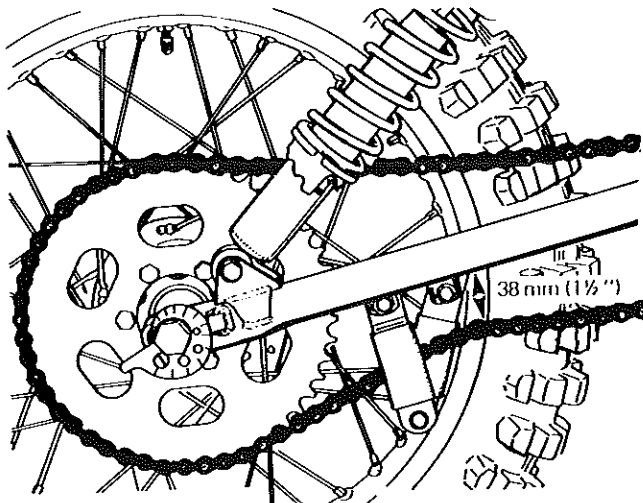

NOTE: Master link clip must be installed with its closed end facing the direction of travel.

TRANSMISSION OIL LEVEL

With the motorcycle in a vertical position, remove the transmission oil level plug and check the oil level.

Oil level should be to the level plug. Add oil through filler / vent plug if necessary. (SAE 80, gear oil).

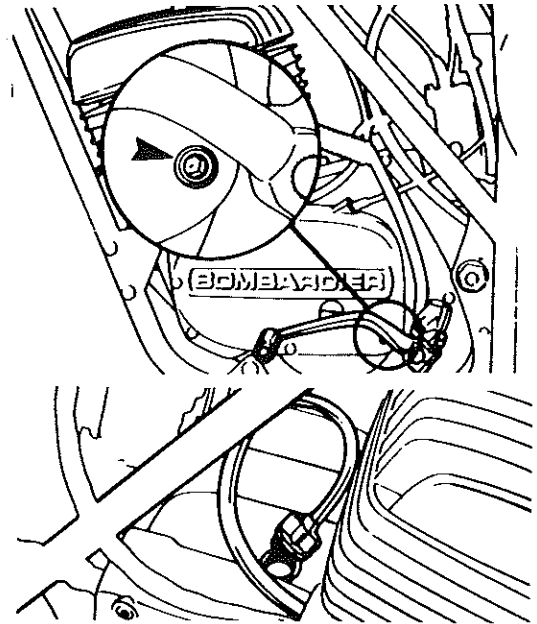

BRAKE ADJUSTMENT

Front

Completely loosen the brake cable adjuster (at handlebar), then using the adjuster located at the brake plate, adjust the cable to provide 25 mm (1") of free lever travel at handlebar.

NOTE: Use adjuster at handlebar for final adjustment.

Rear

Turn the cable adjusting nut until the brake pedal free travel is 25 mm (1").

NOTE: The brake pedal height can be adjusted as desired by moving the stopper.

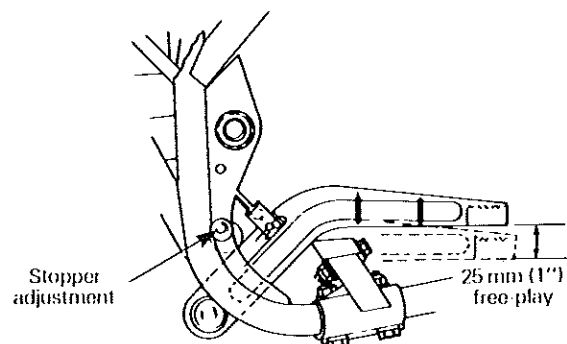

CARBURETOR ADJUSTMENT

Idle speed and mixture adjustment

With the motorcycle held in a vertical position, gently turn air mixture adjusting screw in until it stops, then back it out to 1 ¼ turn.

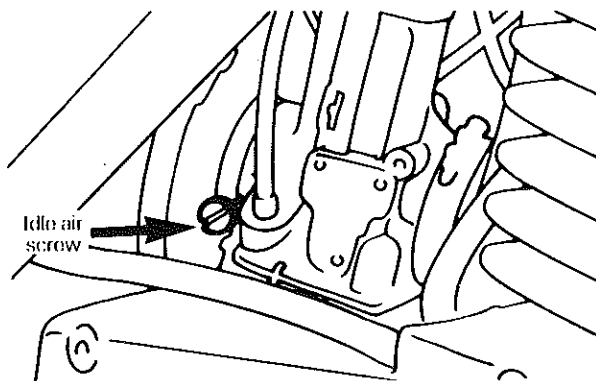

Start the engine and allow it to warm.

Adjust idle speed screw in or out for desired idle speed (Approximately 1,000 R.P.M.)

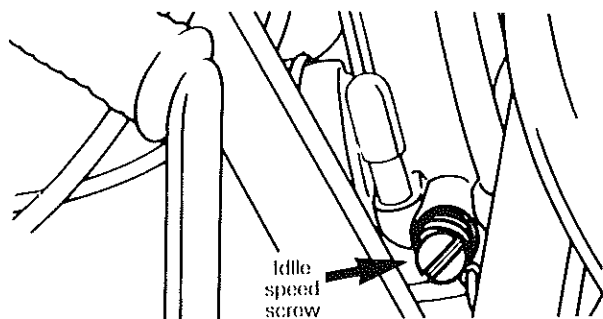

○ NOTE: The air mixture screw can be turned in or out (within ¼ turn of basic setting) to achieve smoothest idle possible. Re-adjust idle speed if necessary.

ENGINE TIMING

Timing mark verification

Disconnect the spark plug wire and remove the spark plug.

Remove the inspection plug on the magneto cover.

Install and adjust the top dead center gauge.

Rotate the rear wheel counter-clockwise until the piston is at 1.2 mm \pm 0.2 (.047" \pm .007) before top dead center.

Check through the inspection hole, the flywheel / rotor and the magneto cover marks must align perfectly.

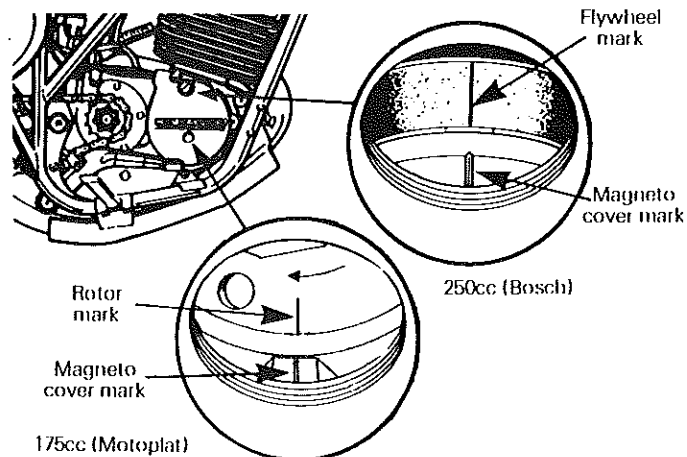

If the marks do not align, scribe a new mark on the magneto cover in line with the flywheel / rotor mark at 1.2 mm \pm .2 (.047" \pm .007) before top dead center.

▼ CAUTION: The timing mark verification cannot be used as a timing procedure therefore always check the timing (using a stroboscopic timing light at 9000 R.P.M.) after the marks have been aligned.

Re-install the spark plug and connect the high tension spark plug wire.

Timing light procedure

Remove the timing inspection plug, and connect the timing light pick-up to the high tension wire.

Start the engine and allow it to warm.

◆ WARNING: To prevent powerful electric shock, do not touch the high tension wire while the engine is running.

Point the timing light beam straight into the inspection hole and briefly rev the engine to 9000 R.P.M. The timing marks on the magneto cover and on the flywheel / rotor should align. Stop the engine.

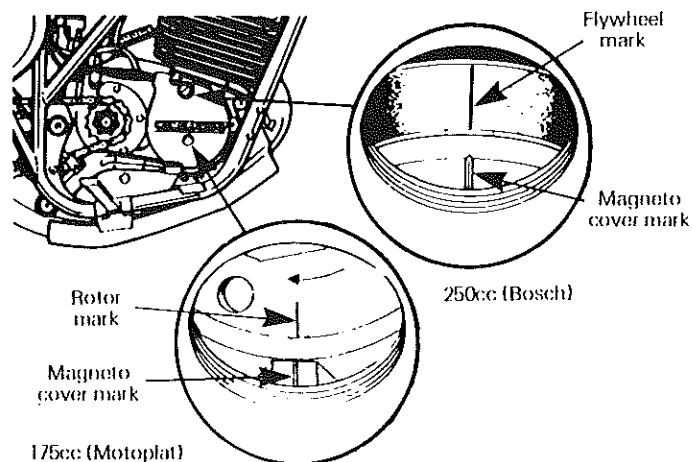

CAUTION: Timing marks must be checked with a dial indicator for perfect accuracy.

If the timing marks do not align, remove the magneto cover, slacken the stator plate retaining screws and move the stator plate in the advance or retard direction to correct the misalignment.

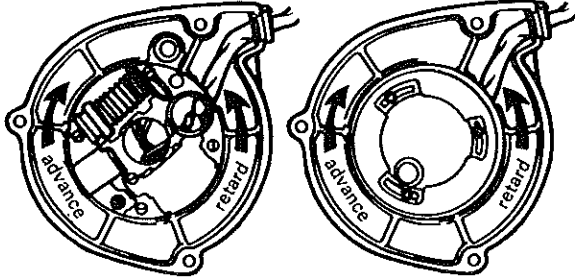

250cc (Bosch)

175cc (Motoplant)

NOTE: Only stroboscopic timing lights utilizing a capacitor or inductive pick-up can be used to indicate correct spark setting without disturbing the electronic equilibrium of the ignition circuit.

Examples of suitable lights:

Sun PTL 45
Snap-on MT215B
Bosch EFAW 169A

TIRE PRESSURE

Check and adjust as required.

The recommended pressure is:

Terrain conditions

| | |
|-------------------------|---|
| Dry, rocky terrain | Front: 84 kPa (12 P.S.I.) Rear: 84 kPa (12 P.S.I.) |
| Soft, wet muddy terrain | Front: 70 kPa (10 P.S.I.) Rear: 70 kPa (10 P.S.I.) |

TEST RIDE MOTORCYCLE

Fill the oil reservoir with injection oil, and the gas tank with premium gasoline only.

Start the motorcycle and test ride briefly for abnormal noises or faulty operation. Run through all the gears, checking for performance, braking and handling, etc... Note the suspension action and throttle response.

Clean the vehicle thoroughly. Explain the operator manual to the customer.

NOTE: Make sure the customer is well aware of the engine break-in procedure.

FIRST FIVE HOURS

- Do not run the engine at excessive R.P.M.
- Shift gears frequently to keep the engine running freely at a moderate R.P.M. range without subjecting it to extreme loads (lugging, overrevving, etc.).
- Make any necessary corrections or adjustments of controls, spokes, drive chain, etc.
- Check for loose nuts, bolts and fasteners. Tighten them if necessary.

1977 MX-3 PRE-DELIVERY TECHNICAL DATA

| | |
|--|---|
| Throttle & injector pump synchronization | 1.6 mm ($\frac{1}{16}$ ") free-play at carburetor top. Marks must align on injection pump. |
| Clutch adjustment | At engine: $\frac{1}{4}$ turn counter-clockwise before point of contact. At handlebar: 1.6 mm ($\frac{1}{16}$ ") free-play between clutch lever and housing. |
| Chain adjustment | Top run of the chain at 38 mm ($1\frac{1}{2}$ ") distance from the swing arm. |
| Brake adjustment | 25 mm (1") of free-play at end of lever or pedal. |
| Transmission oil level | Up to level plug (SAE 80, gear oil). |
| Ignition timing at 9000 R.P.M. | Timing marks of magneto cover and flywheel / rotor must align. |
| Basic timing | 1.2 mm (.047") before top dead center. |
| Tire pressure | Dry, rocky terrain Front: 84 kPa (12 P.S.I.) Rear: 84 kPa (12 P.S.I.) Soft, wet muddy terrain Front: 70 kPa (10 P.S.I.) Rear: 70 kPa (10 P.S.I.) |

CARBURETOR SPECIFICATIONS

| | |
|----------------------------|-----------------------------------|
| Vehicle model | MX-3 175-250cc (No's 7854 & 7864) |
| Carburetor | 1-32-104 |
| Std. main jet (production) | 155 |
| Needle jet | 270 |
| Idle jet | 40 |
| Needle identification | 4 rings |
| Needle setting | 3rd groove from top |
| Slide | No. 1 |
| Air screw | $1\frac{1}{4}$ turn out |
| Float level | 25 mm (1") |
| Idle speed | 1000 R.P.M. |



Service Bulletin

no. 77-2

Date: February 15, 1977

Subject: A) Carburetor flooding
B) Carburetor with two vent lines

Serial nos: 7851,7861,7845,7855,7865

Models: T'NT & Qualifier

A) CARBURETOR FLOODING

If flooding is noticed while riding down steep hills, idling for a prolonged period of time, etc., we recommend to replace the standard float for a less dense model (black) p/n 420 963 192.

Proceed as follows:

Remove the carburetor from the engine.

▼ **CAUTION:** Exercise care when handling throttle slide. If damaged replace.

Remove float chamber and gasket from carburetor.

Push the retaining pin out to release the float and install the new less dense float (black). Reinstall the retaining pin.

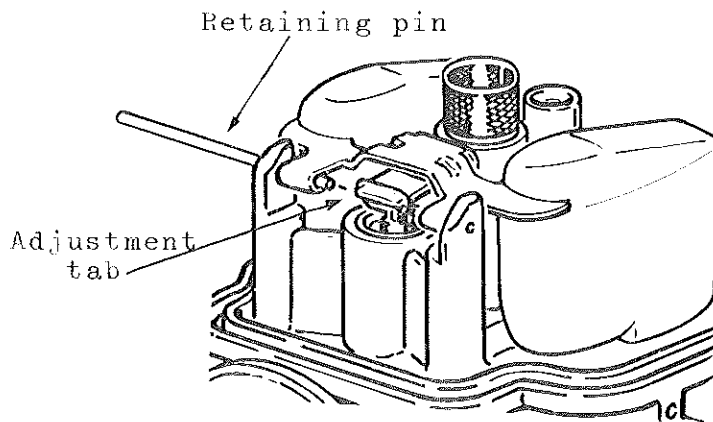

Adjust float level to 25 mm (1").

With carburetor on its side and with float adjustment tab just touching needle, measure distance between top of float and float chamber body (from the bottom of gasket groove).

() To adjust, carefully bend adjustment tab of float arm until specified height is reached.

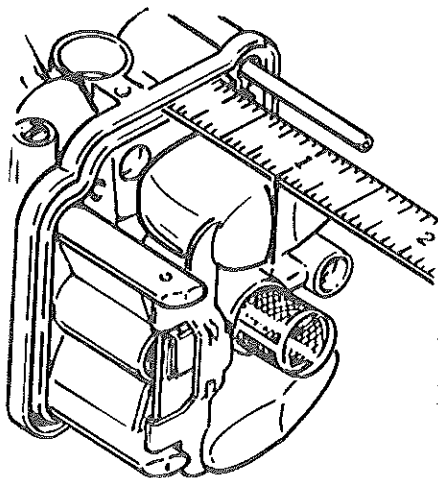

Measure with
a ruler the
height of the
float

B) CARBURETOR WITH TWO VENT LINES

() On any carburetor equipped with two vent lines, connect one to the breather tree (located on the ignition coil bracket) and block the other one properly. This will prevent water entry.

○ NOTE: If the engine runs rich at idle, use a 35 pilot jet.

THIS BULLETIN IS PUBLISHED FOR INFORMATION PURPOSES.

TECHNICAL INFORMATION CENTRE



Service Bulletin

no. 77-3

Date: February 28, 1977

Subject: E-box protection boot, exhaust mounts, wires routing

Serial nos: 7851, 7861, 7845,
7855, 7865

Models: Qualifier & T'NT

At pre-delivery or during inspection, the following points should be more closely inspected and revised if necessary.

- Check that the electronic box protection boot is properly positioned, it may be necessary to loosen the lower mounting nut to correctly reposition the boot.
- Check and make sure all the exhaust system mounts are properly aligned. Torque the exhaust mounts to .4-.5 kg-m (3-4 ft-lbs).

▼ **CAUTION:** Do not overtighten the muffler rear upper mount retaining nut, damage may occur. Torque the nut to .7-.8 kg-m (5-6 ft-lbs).

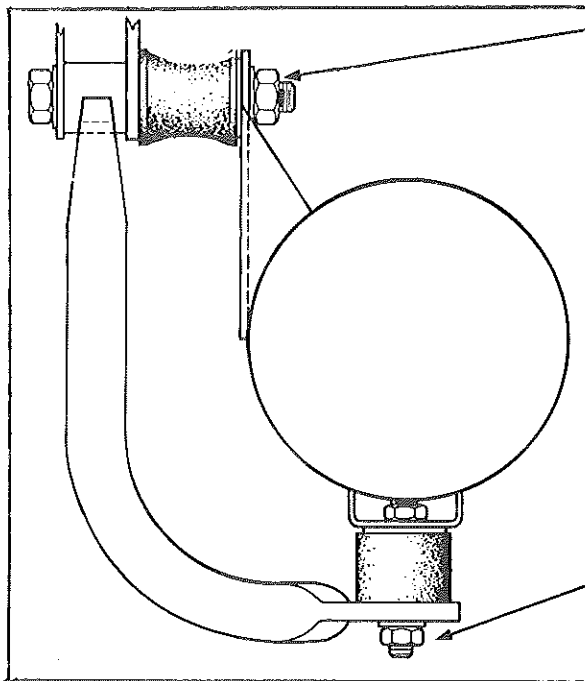

Torque to .7-.8 kg-m (5-6 ft-lbs)

Torque to .4-.5 kg-m (3-4 ft-lbs)

- On the T'NT models, the taillamp and flasher wires should be routed

.../2

in between the taillamp mount and mount holder.

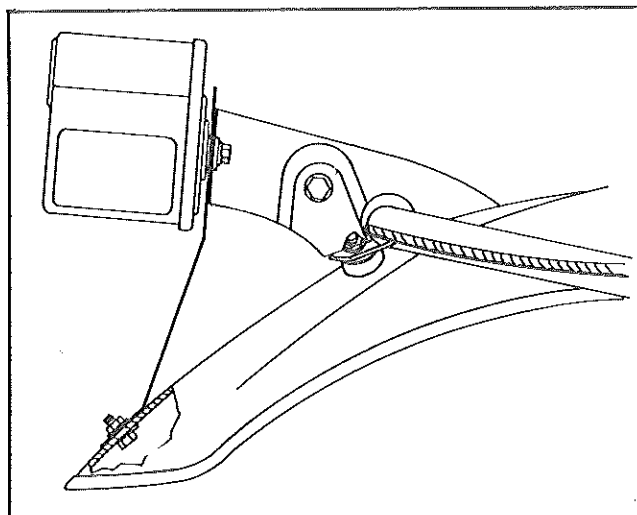

THIS BULLETIN IS PUBLISHED FOR INFORMATION PURPOSES.

TECHNICAL INFORMATION CENTRE



Service Bulletin

no. 77-4

Date: February 25, 1977

Subject: 124 cc piston rings

Serial nos: All

Models: All

When re-ordering new "L" trapez rings for 124 cc engines, make sure to order using the new part numbers mentioned below.

| <u>New part number</u> | <u>Supersedes</u> | <u>Old part number</u> |
|------------------------|-------------------|------------------------|
| <u>420 215 105</u> | 54 mm | 420 215 110 |
| <u>420 215 106</u> | 54.25 mm | 420 215 111 |
| <u>420 215 107</u> | 54.50 mm | 420 215 112 |
| <u>420 215 108</u> | 54.75 mm | 420 215 113 |

Up to engine serial number 58699.

The "R" ring part numbers are unchanged :

| | |
|-------------|----------|
| 420 215 170 | 54 mm |
| 420 215 171 | 54.25 mm |
| 420 215 172 | 54.50 mm |
| 420 215 173 | 54.75 mm |

○ NOTE: Please make the necessary changes in your parts catalog.

THIS BULLETIN IS PUBLISHED FOR INFORMATION PURPOSES.

TECHNICAL INFORMATION CENTRE



Service Bulletin

no. 77-5

Date: March 8, 1977

Subject: Fuel tank rubber mount

Serial nos: From 7865 000725 to
7865 001400 incl.

Models: Qualifier 250

At pre-delivery or during inspection, check that the fuel tank rubber mounts are properly tightened.

If loose, proceed as follows:

Disconnect the fuel line at the carburetor.

Remove the seat and unfasten the fuel tank rubber mount retaining nuts.

Remove the fuel tank and ensure that the mounts are securely tightened into the fuel tank.

Re-install the gas tank and torque the retaining nuts to .4-.5 kg-m (3-4 ft-lbs).

Re-install the seat and connect the fuel line to the carburetor.

THIS BULLETIN IS PUBLISHED FOR INFORMATION PURPOSES.

TECHNICAL INFORMATION CENTRE