

FOR OFFICIAL USE ONLY
CROWN COPYRIGHT RESERVED



MOTOR CYCLE, LIGHTWEIGHT, 250 CC, CAN-AM

MODIFICATION INSTRUCTIONS

BY COMMAND OF THE DEFENCE COUNCIL

Frank Cooper.

Ministry of Defence

MODIFICATION INSTRUCTION INDEX

This index is to be kept up to date by the User entering modification instructions as and when they are published.

Priority (Pty) is shown as: Immediate: I Routine: R

Mod No	Pty	Subject	Approval No/ Remarks
1	I	Fuel tank mounting	Task 519
2	I	IMPROVED CANVAS PANNIER BAC. ASSY.	TASK 492.
3	R	IDENTIFICATION OF POS BATT. CABLE	MACS 16/012
4	R.	STRG. HD. LUBRICATION.	
5	R	RE-POSITIONING OF FIRE EXTINGUISHER.	
6	R	CENTRE STAND AND STOP PLATES	
7	R.	CATCH RELEASE MECHANISM.	
8	R.	CANVAS PANNIER BAC.	TASK 576.
9	R.	IMPROVED BREATHER. ALT HOUSING & G/BOX.	TASK. 557.
10	R	SWITCH IGN & LIGHTING	TSS 5203.
11			
12			
13			
14			
15			
16			
17			
18			
19			
20			

TITLE MOTOR CYCLE, LIGHTWEIGHT, 250 CC, CAN-AM

MODIFICATION INSTRUCTION NO 1

Sponsor:
DGEME(A)
File ref: VB/55706/32
Data Centre Code BVT7B

Publications Authority:
Vehicles Branch REME
Project No: 70512 (166)

AMENDMENT RECORD

Amdt	Incorporated by	Date	Amdt	Incorporated by	Date
1			4		
2			5		
3			6		

SUBJECT: Fuel tank mounting
(Task No 519)

INTRODUCTION

1 This instruction introduces additional packing to the fuel tank mounting, to prevent fuel tank fouling oil indicator tube.

1.1 Limitations on use of equipment. NIL

APPLICABILITY

2 Fuel tank mounting assembly

2.1 Fitted to subject vehicles (Code No 1010-0746 and 1010-5746 of Contract No FVE 22A/36 held by user units.

2.2 Unmodified stock, held in RAOC and technical stores.

REASON FOR MODIFICATION

3 Code 1 - to improve safety

PRIORITY

4 ARMY: Immediate
RAF: Class 2

ESTIMATED TIME REQUIRED

5 Embodiment: 2 man-hours

MODIFICATION IMPLEMENTATION PLAN

6

6.1 This modification is to be implemented by:

ARMY - Units authorized to carry out levels 2, 3 and 4 maintenance.

RAF - Immediately on receipt of mod set and Vehicle Depots before issue of vehicle.

6.2 Associated modification instructions. NIL

6.3 Modification plate strike action. NA

Action required by:

7

7.1 Units and establishments holding equipment

7.1.1 Examine vehicle documents to see if modification is applicable.

7.1.2 Examine equipment to see if modification is embodied and where necessary demand the stores required.

7.1.3 ARMY - On receipt of stores, request REME to modify equipment.

7.1.4 ARMY - Record the modification AESP number and Army Modification Code in equipment documents AB G562

RAF - Record modification details on RAF Form 4870.

7.2 Army units authorized to carry out levels 2, 3 and 4 maintenance, and RAF units

7.2.1 ARMY - When requested by users or during overhaul, obtain the items listed in para 8 and carry out this modification.

RAF - On receipt of stores, embody the modification.

7.2.2 Record completion details of modification against appropriate entry in equipment documents.

7.2.3 Complete AF G1084A when reporting completion of the modification to Data Centre using the following FORWARD codes:

ARMY: EQUIPMENT CODE: See para 2.1
MODIFICATION CODE: X 00001

RAF: MODIFICATION CODE: AFK 010

Stores, tools and equipment

8 Stores to be demanded

8.1 The following modification set is to be demanded quoting this instruction as authority for demand, and

8.2 Registration number of vehicle held by user units.

8.3 Registration number of vehicles of unmodified stock held in RAOC and technical stores.

<u>Item No</u>	<u>COSA Section</u>	<u>NSN/Part No</u>	<u>Designation</u>	<u>Qty per veh</u>
	LV7/BDR	2910-99-836-0836	Mod set: Fuel tank mounting comprising:	1
1			Spacer steel 6 mm i.d. x 1 in. o.d. x 3/16 in. thk	(2)
2			Pad, rubber self adhesive	(2)

Sequence of operations

9 Carry out the modification as follows:

9.1 Remove and retain seat with fixings.

9.2 Close petrol tap and remove petrol pipe from rear of tap.

9.3 Remove and retain fuel tank with fixings from frame, ensuring that the earth lead attached to the r.h. mounting is carefully removed and placed to one side.

9.4 Unscrew the two resilient mounts from the base of the fuel tank, fit one spacer (item 1) to each mount as detailed in Fig 1 and refit mounts to fuel tank.

9.5 Reposition existing foam pads with additional pads (item 2) on frame as detailed in Fig 1.

9.6 Remove oil level indicator tube from oil pipe line, reset end of pipe line as shown in Fig 1 and refit indicator tube.

9.7 Refit fuel tank to frame ensuring that it is fitted as far to the rear as resilient mounts will allow and that there is sufficient clearance between rear of tank and oil level indicator tube.

Note ...

If there is insufficient clearance increase the offset of the oil pipe line.

9.8 Refit earth lead to r.h. resilient mount stud and secure tank to frame with existing fixings. Refit petrol pipe to rear of petrol tap. Refit seat.

Testing after embodiment

10 Nil

EFFECT ON WEIGHT

11 Negligible

PUBLICATION AMENDMENTS

Note ...

Necessary amendment will be issued separately.

12 IPC reference No 2340-K-201-701 will be amended in due course.

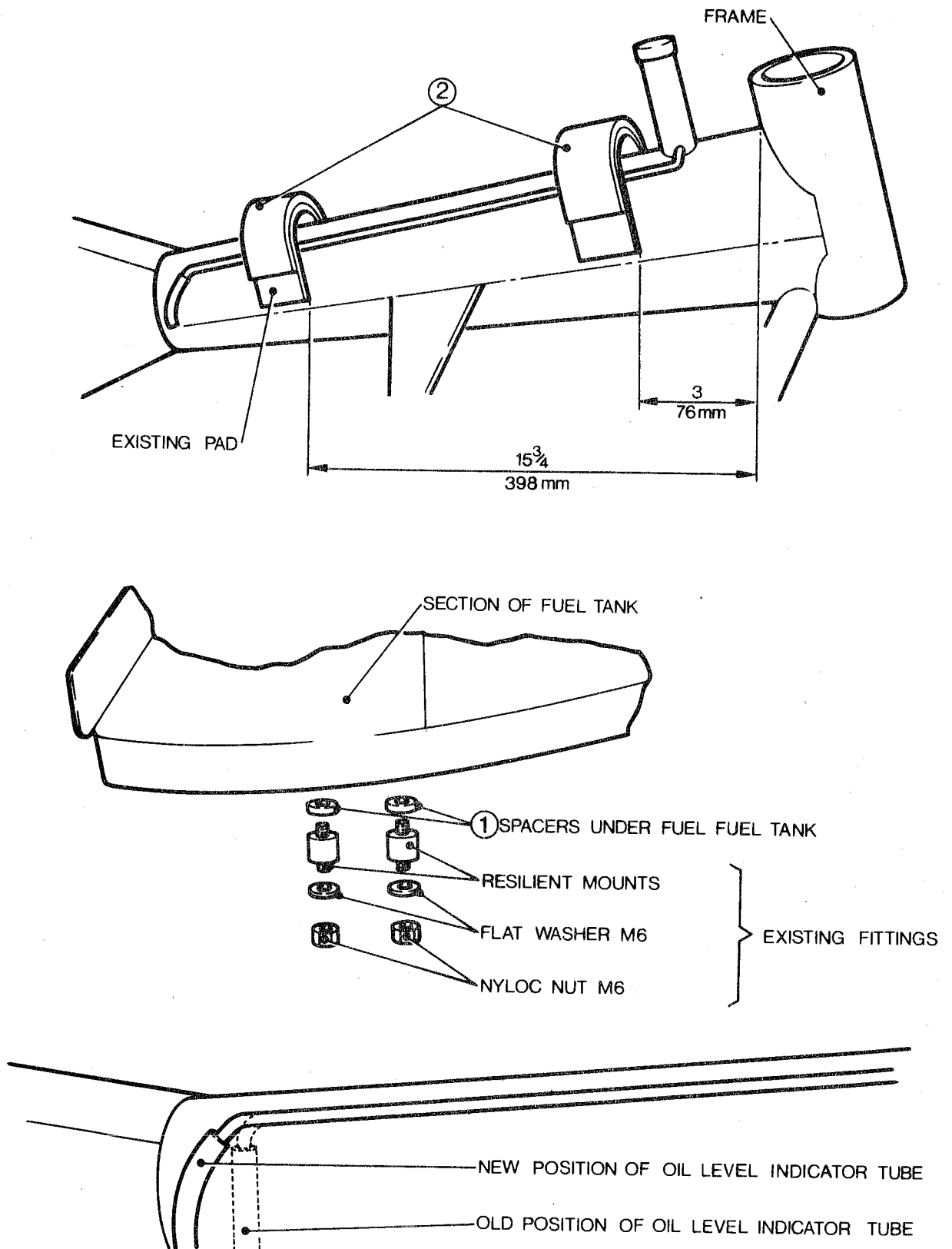

Fig 1 - Fuel tank mounting
(Dimensions in inches)

V5196/1

70512 (166)
Veh Br 55706/32 Task 519
Data Centre Code BVT7B

END - Instr No 1



MOTOR CYCLE LIGHT WEIGHT 250 CC CAN-AM
MODIFICATION INSTRUCTION NO 2

SUBJECT Improved amperage detector assy

CANCELLATION

INTRODUCTION

1 Modification Instruction No 2 dated May 81 is hereby cancelled. Mod Set is no longer available.

ACTION

2 File this page 1/2 in place of Mod Instr No 2 dated May 81, all pages of which are to be destroyed.

Vehs & Wpns Br
70911 (241)

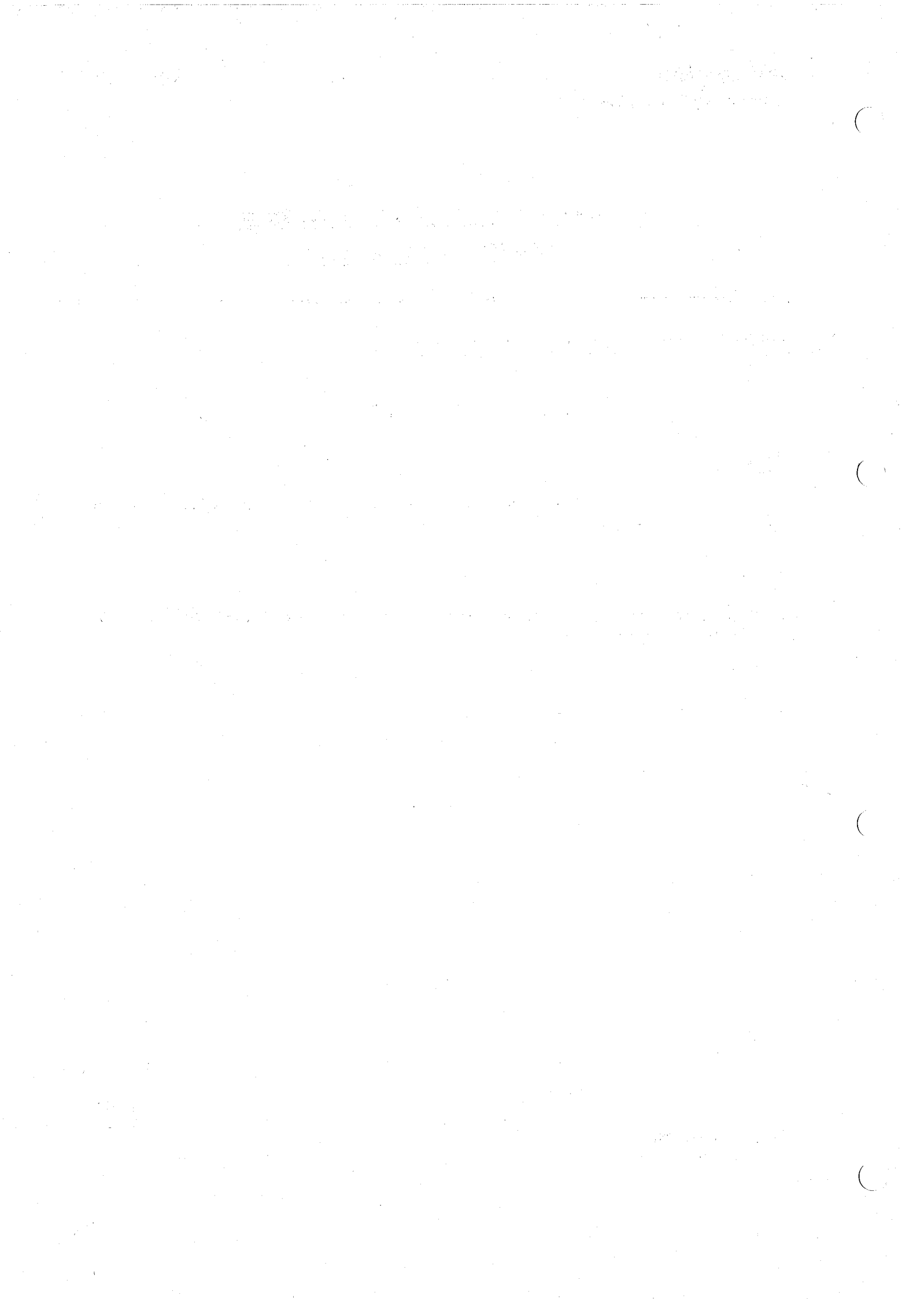

MOTOR CYCLE, LIGHTWEIGHT, 250 CC, CAN-AM

MODIFICATION INSTRUCTION NO 3

Sponsor:
DGEWE(A)
Data Centre Code BVT7B

Publications Authority:
Vehicles Branch REME
Project No: 70612 (97)
File ref: 55706/33

AMENDMENT RECORD

Amdt	Incorporated by	Date	Amdt	Incorporated by	Date
1			4		
2			5		
3			6		

SUBJECT: Identification of positive battery cable
(MACS 16-012)

INTRODUCTION

1 This instruction introduces three alternative methods to improve the identification of the positive battery cable. The method selected will depend upon the availability of the specialist tools required, ie heating tool or terminal crimping pliers. It may also be found that with the introduction of a later type battery the battery cables are not long enough to reach the terminals, this can be overcome by re-routing the cables.

APPLICABILITY

2 Motor cycle, Lightweight, 250 cc, Can-Am VACs: 1010-0746, 1010-5746, 1015-0746 - Contract number FV 22A/36 only.

REASON FOR MODIFICATION

3 Code 4 - to improve maintainability.

PRIORITY

4 ARMY: Routine, when next the battery is disconnected.
RAF : Class 3 - when next the battery is disconnected.

ESTIMATED TIME REQUIRED

5 Embodiment: 1/2 man-hour

MODIFICATION IMPLEMENTATION PLAN

6
6.1 This modification is to be implemented by:

ARMY - Units authorised to carry out levels 2, 3 and maintenance.

RAF - At the next Minor or Major servicing or when the battery is next disconnected, whichever is the sooner.

6.2 Associated modification instructions: NIL

6.3 Modification plate strike action: NA

Action required by:

7

7.1 Units and establishments holding equipment

7.1.1 Examine relevant documents to see if this modification is applicable.

7.1.2 Examine equipment or modification record plate to see if modification is embodied and where necessary demand the stores required.

7.1.3 ARMY - On receipt of stores request REME to modify equipment.

7.1.4 ARMY - Record the modification AESP number and Army Modification Code in equipment documents.

RAF - Record modification details on RAF F4870.

7.2 Army units authorised to carry out levels 2, 3 and 4 maintenance, and RAF units

7.2.1 ARMY - When requested by users or during overhaul, obtain the items listed in para 8 and carry out this modification.

RAF - On receipt of stores, embody this modification.

7.2.2 Record completion details of modification against appropriate entry in equipment documents.

7.2.3 Complete AF G1084A when reporting completion of the modification to Data Centre using the following FORWARD codes:

ARMY: EQUIPMENT CODE Refer to EMER Mgmt J 022
MODIFICATION CODE: X 00184

RAF: MODIFICATION CODE: A F K 012

7.3 All recipients of this instruction. Add particulars to AESP 2340-K-201-811 Mod Instr Index.

Stores, tools and equipment

8

8.1 Stores to be demanded

8.1.1 The following items are to be demanded quoting this instruction as authority for demand, and

8.1.2 Registration number of vehicle.

Note ...

Which items are demanded will depend upon which method of implementation is selected.

<u>Item No</u>	<u>COSA Section</u>	<u>NSN/Part No</u>	<u>Designation</u>	<u>Qty per eqpt</u>
1	Z42	5970-99-434-2051	Heat shrink sleeve, red 1/4 in. od	30 mm
2	Z42	5975-99-910-7545	Sleeve ident	3
3	Z42	5975-99-104-5478	Sleeve split, red	3

Sequence of operations

9 Carry out the modification as follows:

9.1 Method A, to be used if a heat shrinking tool is available. Identify the positive battery lead, place a 30 mm length of heat shrink sleeve (item 1) on the lead, next to the battery eyelet terminal, shrink onto the lead.

9.2 Method B, to be used if a heat shrinking tool is not available but crimping pliers are:

9.2.1 Remove the battery eyelet terminal, place 3 sleeve ident (item 2) onto the battery lead, crimp on a replacement eyelet terminal. Slide the 3 ident sleeves up the battery lead so that they are as near to the eyelet as possible, 3 sleeves are required due to the size of the sleeves.

9.3 Method C, to be used if a heat shrinking tool and crimping pliers are not available:

9.3.1 Open the sleeves split red (item 3) and fit them to the battery lead as near to the eyelet as possible, again 3 sleeves are required due to the size of the sleeves.

Testing after embodiment

10 Nil

EFFECT ON WEIGHT

11 Negligible

PUBLICATION AMENDMENTS

12 Nil

END

u
m

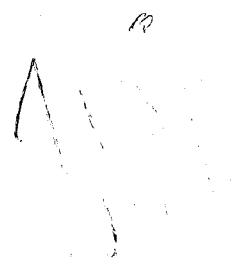

MOTOR CYCLE, LIGHT WEIGHT, 250 CC, CAN-AM

MODIFICATION INSTRUCTION No 4

Sponsor:
DGEME(A)
Data Centre Code BVT7B

Publications Authority:
Vehicles Branch REME
Project No: 70612 (103)
File ref: VB 55706/34

AMENDMENT RECORD

Amdt	Incorporated by	Date
1		
2		
3		

Amdt	Incorporated by	Date
4		
5		
6		

SUBJECT: Steering head lubrication (MACS No 16-016)

INTRODUCTION

1 This instruction introduces a lubrication nipple to lubricate the steering head bearings, thus obviating the risk of steering head seizure.

APPLICABILITY

2 Motor cycle, 250 cc, Can-Am, VACs: 1010-0746, 1010-5746, 1015-0746, of Contract No FVE 22A/36 and 22A/88.

REASON FOR MODIFICATION

3 Code 4 - to improve maintainability.

PRIORITY

4 ARMY: Routine
RAF: Class 3

ESTIMATED TIME REQUIRED

5 Embodiment 1 man-hours

MODIFICATION IMPLEMENTATION PLAN

- 6 6.1 This modification is to be implemented by:
- ARMY - Units authorised to carry out levels 2, 3 and 4 maintenance.
- RAF - Units not later than the next lubrication servicing and Vehicle Depots before issue of vehicle.
- 6.2 Associated modification instructions. Nil.
- 6.3 Modification plate strike action: NA

Action required by:

- 7 7.1 Units and establishments holding equipment
- 7.1.1. Examine relevant documents to see if this modification is applicable.
- 7.1.2. Examine equipment to see if modification is embodied and where necessary demand the stores required.
- 7.1.3. ARMY - On receipt of stores request REME to modify equipment.
- 7.1.4. ARMY - Record the modification AESP number and Army Modification Code in equipment documents.
- RAF - Record modification details on RAF F4870.
- 7.2 Army units authorised to carry out levels 2, 3 and 4 maintenance, and RAF units.
- 7.2.1. ARMY - When requested by users or during overhaul, obtain the items listed in para 8 and carry out this modification.
- RAF - On receipt of stores, embody this modification.
- 7.2.2. Record completion details of modification against appropriate entry in equipment documents.
- 7.2.3. Complete AF G1084A when reporting completion of the modification to Data Centre using the following FORWARD codes;
- | | | |
|-------|-------------------|---------------------|
| ARMY: | EQUIPMENT CODE: | Refer to Mgmt J 022 |
| | MODIFICATION CODE | X 00188 |
| RAF: | MODIFICATION CODE | A F K O 1 3 |
- 7.3 All recipients of this instruction. Add particulars to AESP ref 2340-K-207-811 Mod Instr Index.

Stores, tools and equipment

8 Stores to be demanded

8.1 The following item is to be demanded quoting this instruction as authority for demand, and

8.1.1 Registration number of vehicle held by user units.

8.1.2 Registration number of vehicle or scaling schedule for unmodified stock held in RAOC and technical stores.

<u>Item No</u>	<u>COSA Section</u>	<u>NSN/Part No</u>	<u>Designation</u>	<u>Qty per eqpt</u>
1	LV6MT1	4730-99-943-9374	Lubricating nipple 1/4 inch UNF thread	1

Sequence of operations

9 Carry out the modification as follows:

9.1 Turn the front forks to full right hand lock, identify the steering head. It will be seen that the motor cycle frame number is now fully exposed.

9.2 The lubrication nipple is to be located 3.1/8 inches from the top of the steering head, ie, centrally on the axis of the steering head tube between the motor cycle frame number and the weld which retains the steering head tube to frame. When this point has been identified it is to be marked with a centre punch.

9.3 When carrying out this step of the instruction care should be exercised to ensure that no swarf enters the steering head. Drill a 13/64 inch dia hole in the steering head at the point marked with the centre punch in the previous paragraph. The drill should be coated with grease to retain any swarf, thus preventing the swarf from entering the steering head. Care should be taken to ensure that the frame engine oil tank is not pierced during this operation.

9.4 Using a 1/4 inch dia UNF tap, tap the hole drilled in the previous paragraph, again the tap should be coated with grease to prevent the swarf from entering the steering head.

9.5 Fit the lubricating nipple (item 1), lubricate the steering head using Grease XG 279.

Testing after embodiment

10 Ensure that the grease reaches both top and bottom steering head bearings.

EFFECT ON WEIGHT

11 Negligible.

PUBLICATION AMENDMENTS

12 The necessary amendments will be issued separately.

END - Instr No 4

10/10/20

(1)

(1)

(1)

(1)

MOTOR CYCLE, LIGHT WEIGHT, 250 cc, CAN-AM

MODIFICATION INSTRUCTION NO 5

Sponsor:
DGEME (A)

Data Centre Code: BVT 7B

Publications Authority:
Vehicles Branch REME
Project No: 70612 (119)
File ref: 55706/35

AMENDMENT RECORD

Amdt	Incorporated by	Date	Amdt	Incorporated by	Date
1			4		
2			5		
3			6		

SUBJECT: Re-positioning of fire extinguisher

(MAE 16-017)

INTRODUCTION

1 A large number of the subject vehicles have entered service with the BCF fire extinguisher mounted on the panniers. The panniers are manufactured from fibre glass, which cracks and breaks up under the stresses imposed by the fire extinguishers and when the panniers are removed, so is the fire extinguisher. This instruction details the re-positioning of the fire extinguisher.

APPLICABILITY

2 Motor cycle, 250 cc, Can-Am, VACS: 1010-0746, 1010-5746, 1015-0746, all of Contract 22A/36 where the fire extinguisher is fitted on the pannier.

REASON FOR MODIFICATION

3. Code 6 - to prevent damage to panniers

PRIORITY

4 ARMY: Routine
RAF: Class 3

ESTIMATED TIME REQUIRED

5 Embodiment: 3 man-hours

MODIFICATION IMPLEMENTATION PLAN

6

6.1 This modification is to be implemented by:

ARMY - Units authorized to carry out levels 2, 3 and 4 maintenance.

RAF - Units not later than the next lubrication servicing and Vehicle Depots before issue of vehicle.

6.2 Associated modification instructions: Nil

6.3 Modification plate strike action: NA

Action required by:

7

7.1 Units and establishments holding equipment

7.1.1 Examine relevant documents to see if this modification is applicable.

7.1.2 Examine equipment to see if modification is embodied and where necessary demand the stores required.

7.1.3 ARMY - On receipt of stores request REME to modify equipment.

7.1.4 ARMY - Record the modification AESP number and Army Modification Code in equipment documents.

RAF - Record modification details on RAF F4870.

7.2 Army units authorized to carry out levels 2, 3 and 4 maintenance, and RAF units

7.2.1 ARMY - When requested by users or during overhaul, obtain the items listed in para 8 and carry out this modification.

RAF - On receipt of stores, embody this modification.

7.2.2 Record completion details of modification against appropriate entry in equipment documents.

7.2.3 Complete AF G1084A when reporting completion of the modification to Data Centre using the following FORWARD codes:

ARMY: EQUIPMENT CODE: Refer to Mgmt J O22
MODIFICATION CODE: X 00198

RAF: MODIFICATION CODE: A F K 014

7.3 All recipients of this instruction. Add particulars to AESP ref 2340-K-201-811 Mod Instr Index.

Stores, tools and equipment

8

8.1 Stores to be demanded. The following items are to be demanded quoting this instruction as authority for demand, and

8.1.1 Registration number of vehicle held by user units.

8.1.2 Registration number of vehicle for unmodified stock held in RAOC stores.

<u>Item No</u>	<u>COSA Section</u>	<u>NSN/Part No</u>	<u>Designation</u>	<u>Qty per eqpt</u>
1	G2	9515-99-964-7279	Steel strip carbon 40 mm x 3 mm or suitable alternative	203 mm
2	G1	5305-99-941-8871	Screw 2 BA x 1/2 in. countersunk	3
3	G1	5310-99-941-7070	Nut 2 BA	3

Sequence of operations

9 Carry out the modification as follows:

9.1 Remove the fire extinguisher from the bracket, remove the bracket from the pannier and retain both items. The securing devices are to be discarded. The holes left in the pannier are to be made good using a suitable fibre glass repair product.

9.2 Refer to Fig 1, manufacture a support plate from steel strip (item 1) to the dimensions shown. Using the fire extinguisher bracket as a template drill three 2 BA clearance size holes in the positions shown, the two holes on the right hand side are to be drilled as near to the end of the plate as possible, allowing enough space to accommodate the nuts.

9.3 Weld the three 2 BA nuts (item 3) to the plate, clean the plate, and paint so as to conform with the paint scheme of the motor cycle.

9.4 Remove the rear portion of the rear mudguard from the vicinity of the motor cycle rear frame loop. This is necessary to ensure that the mudguard is not damaged when the support plate is welded in position.

9.5 Locate the support plate as shown, ensuring that the plate is positioned so as to leave clearance between it and the rear mudguard when it is refitted. Weld the support bracket to the frame, touch up any damaged paintwork. Refit the portion of the mudguard removed in para 9.4.

9.6 Check the fire extinguisher bracket removed in para 9.1 to ascertain if the extinguisher nozzle protection plate has square or rounded corners. If they are square, they are to be worked to a smooth rounded contour.

9.7 Fit the fire extinguisher bracket to the support plate using screws 2 BA item 2), fit the fire extinguisher to the bracket.

Testing after embodiment

10 Nil

EFFECT ON WEIGHT

11 Negligible

PUBLICATION AMENDMENTS

12 Nil

CORNERS TO BE ROUNDED OFF

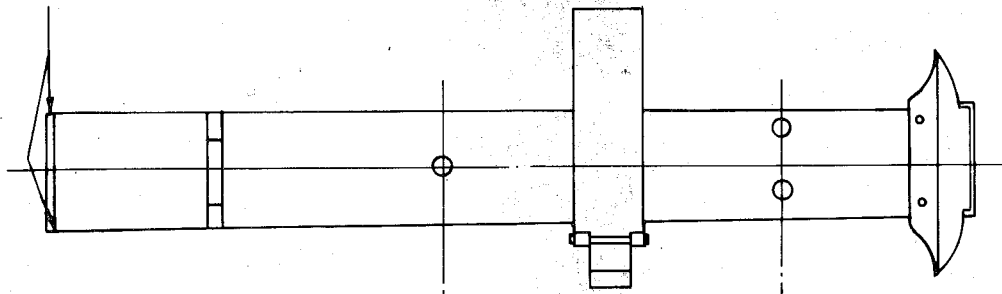

1/8 STEEL
PLATE / STRIP

2 BA NUTS WELDED
TO UNDERSIDE
HOLES DRILLED TO SUIT FIRE
EXTINGUISHER BRACKET

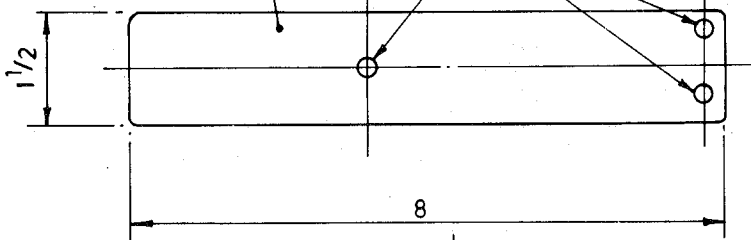

¢
OF BIKE

REAR
FRAME
LOOP

3/4 ¢
OF PLATE

WELD

WELD

WELD

Fig 1 - Fire extinguisher support plate
(Dimensions in inches)

V5626/1

END - Instr No 5

MOTOR CYCLE, LIGHT WEIGHT, 250 cc CAN AM

MODIFICATION INSTRUCTION NO 6

Sponsor:
DGEME (A)
Data Centre Code BVT 7B

Publication Authority:
Vehicles Branch REME
Project No: 70612 (232)
File ref: 55706/36

AMENDMENT RECORD

Amdt	Incorporated by	Date	Amdt	Incorporated by	Date
1			4		
2			5		
3			6		

SUBJECT: Centre stand and stop plates

(MACS 16-018)

INTRODUCTION

1 This instruction refers to the extending of the centre stand legs and the strengthening of the centre stand stop plates to ensure maximum stability when in the parked position.

APPLICABILITY

2 Motor Cycle, light weight, 250 cc Can Am of the following VAC: 1010-0746 1010-5746 and 1015-0746 all of contract number FVE 22A/36.

2.1 Held by user units.

2.2 Unmodified stock held in RAOC and technical stores.

REASON FOR MODIFICATION

3 Code 6 - to improve stability when parked.

PRIORITY

4 ARMY - Routine
RAF - Class 3

ESTIMATED TIME REQUIRED

5 Embodiment: 4.1/2 man-hours

9.6 Fit the manufactured stop plates (item 2) using bolts nuts and washers (items 5, 6 and 8).

9.7 Refit the modified centre stand (item 7) complete with fixings.

9.8 Prepare and paint as necessary.

Testing after embodiment

10 Nil

EFFECT ON WEIGHT

11. Negligible

PUBLICATION AMENDMENTS

12 Nil

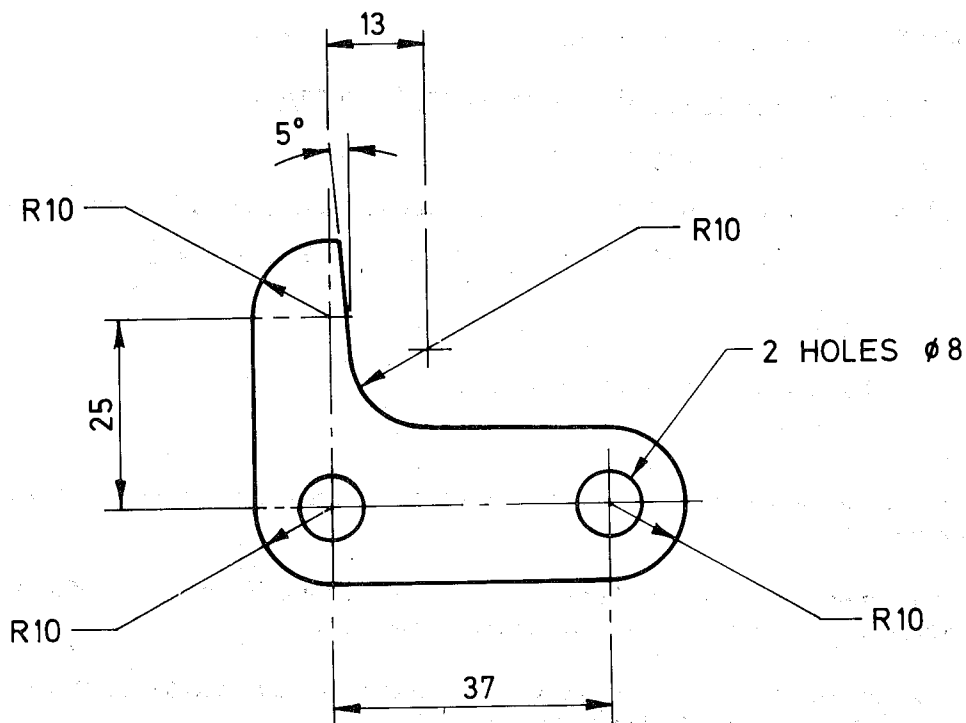

Fig 1 - Centre stand stop plate
(Dimensions in mm)

V5808/1

END - Instr No 6

MOTOR CYCLE, LIGHT WEIGHT, 250 cc CAN AM 250

MODIFICATION INSTRUCTION NO 7

Sponsor:

DGEME (A)
File ref: 55706/37
Data Centre Code: BVT 7B

Publications Authority:

Vehicles Branch REME
Project No: 70712 (134)

AMENDMENT RECORD

Amdt	Incorporated by	Date	Amdt	Incorporated by	Date
1	<i>J. Mullen ssec</i>	<i>11-3-83</i>	4		
2			5		
3			6		

SUBJECT: Clutch release mechanism

(Task No 574)

INTRODUCTION

1 This instruction introduces a replacement hardened cam clutch release, and details the fitting of three steel balls to the clutch cover to be embodied, only when heavy clutch operation is experienced.

1.1 Limitations on use of equipment: Nil.

APPLICABILITY

2 Motor Cycle, light weight, 250 cc Can Am of the following VAC: 1010-0746, 1010-5746 and 1015-0746 all of contract number FVE 22A/36 held by user units.

REASON FOR MODIFICATION

3 Code 2 -- to improve operational performance

PRIORITY

4 ARMY: Routine
RAF: Class 3

ESTIMATED TIME REQUIRED

5 Embodiment: 4 man-hours

MODIFICATION IMPLEMENTATION PLAN

6

6.1 This modification is to be implemented by:

ARMY - Units authorized to carry out levels 3 and 4 maintenance.
RAF - Units when necessary.

6.2 Associated modification instructions: Nil.

6.3 Modification plate strike action: NA.

Action required by:

7

7.1 Units and establishments holding equipment

7.1.1 Examine vehicle documents to see if modification is applicable.

7.1.2 Examine vehicle to see if modification is embodied and where necessary demand the stores required.

7.1.3 ARMY - On receipt of stores, request REME to modify equipment.

7.1.4 ARMY - Record the modification AESP number and Army Modification Code in equipment documents.

RAF - Record modification details on RAF Form 4870.

7.2 Army units authorized to carry out levels 3 and 4 maintenance, and RAF units

7.2.1 ARMY - When requested by users or during overhaul, obtain the items listed in para 8 and carry out this modification.

RAF - On receipt of stores, embody the modification.

7.2.2 Record completion details of modification against appropriate entry in vehicle documents.

7.2.3 Complete AF G1084A when reporting completion of the modification to Data Centre using the following FORWARD codes:

ARMY - EQUIPMENT CODE: See para 2

MODIFICATION CODE: X 00403

RAF - MODIFICATION CODE: AFK 016

7.3 All recipients of this instruction. Add particulars to AESP ref 2340-K-201-811 Mod Instr Index.

Stores, tools and equipment

8

8.1 Stores to be demanded

8.1.1 The following items are to be demanded quoting this instruction as authority for demand, and

8.1.2 Registration number of vehicle held by user units.

<u>Item No</u>	<u>COSA Section</u>	<u>NSN/Part No</u>	<u>Designation</u>	<u>Qty per eqpt</u>
1	6MT7	3110-99-950-0568	Ball steel 7/32 in. Part No 420-232-440	3
2	LV7BDR	2520-99-837-5347	Cam clutch release Pt No 420-259-790	1

8.2 Stores or suitable equivalent to be obtained locally

<u>Item No</u>	<u>COSA Section</u>	<u>NSN/Part No</u>	<u>Designation</u>	<u>Qty per eqpt</u>
3	H1	8030-99-225-0248	Loctite 242	As reqd
4	G2	9510-99-964-7152	Steel bar round	As reqd

8.3 Tools and stores to be manufactured

5			Cylindrical spacer V5976	1
---	--	--	--------------------------	---

8.4 Stores to be removed and reduced to scrap

6	LV7BDR	2520-21-878-8408	Cam clutch release Pt No 420-259-619	1
---	--------	------------------	---	---

8.5 Stores to be modified

7	LV7BDR	2805-21-877-2915	Cover clutch Pt No 420-212-102	1
---	--------	------------------	-----------------------------------	---

Sequence of operations

9 Carry out the modification as follows:

Note ...

The item numbers of para 8 are used as references throughout this instruction.

9.1 From steel bar round (item 4) manufacture a cylindrical spacer (item 5) to the dimensions given in Fig 1.

9.2 Remove the cover clutch (item 7) from the engine and remove and discard the cam clutch release (item 6). Retain remainder of cam assembly. Thoroughly clean cover clutch (item 7).

9.3 Measure and mark off the cover clutch (item 7) as detailed in Fig 1 using method A or B. Once precisely located, centre punch the three hole centres and using a 3.2 mm (1/8 in.) drill bit, drill three starting holes to a depth of 3.2 mm (1/8 in.).

9.4 Install a new 7/32 in. drill bit and the cylindrical spacer on a hand drill. Slide in the drill bit until 5.6 mm (0.220 in.) is protruding over the cylindrical spacer as shown in Fig 1 and tighten the drill chuck. The cylindrical spacer must be leaning against the drill chuck. In order to achieve a hole depth to accurate dimensions of 5.6 mm \pm 0.1 mm (0.220 in. \pm 0.004 in.) a brand new drill but must be used.

9.5 Position the drill bit in the starting holes perpendicular to the surface to be drilled of the cover clutch (item 7) and drill the three holes to equal depths of 5.6 mm (0.220 in.).

9.6 Clean the three holes and drop a small amount of lubricating oil into the holes and install the three steel balls (item 1).

9.7 Fit the hardened cam clutch release (item 2) to the modified cover clutch (item 7) with the retained remainder of the cam assembly. Apply Loctite 242 (item 3) to the cam assembly retaining screw and torque lead to 5.5 Nm (4 lbf/ft).

9.8 Refit the cover clutch (item 7).

9.9 Prior to clutch adjustment the clutch cable access plug must be screwed in, and the clutch lever operated a few times to seat the cable in place.

9.10 Loosen the clutch cable adjuster at handlebar to provide maximum slack, remove the clutch adjustment access plug and loosen the 4 mm set screw.

9.11 Turn the 8 mm clutch adjusting screw in and out to locate the point of contact with release bearing then turn screw 1/2 turn out.

9.12 Carefully tighten the 4 mm set screw to lock the adjustment and replace the access plug.

9.13 Adjust the cable adjuster at handlebar to provide 8-9 mm (5/16 in. - 3/8 in.) slack between clutch lever and housing.

Testing after embodiment

10 Carry out functional road test.

EFFECT ON WEIGHT

11 Negligible

PUBLICATION AMENDMENTS

12 Nil.

METHOD A

METHOD B

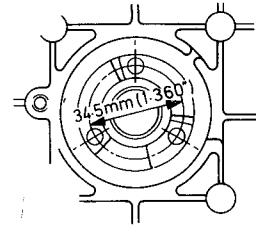
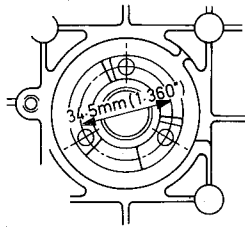

4.4 mm ± 0.1mm
(0.175" ± 0.005")

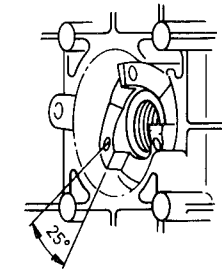
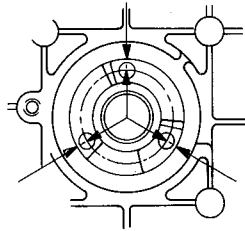

7 mm ± 0.1mm
(0.275" ± 0.005")

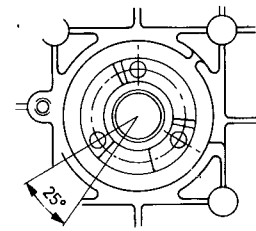
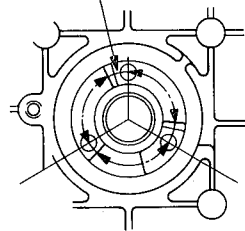

- 1 CYLINDRICAL SPACER:
60 mm (2 3/8") LENGTH (NOMINAL)
8 mm (5/16") OUTSIDE DIA. (NOMINAL)
5.5 mm (7/32") INSIDE DIA. (MAXIMUM)

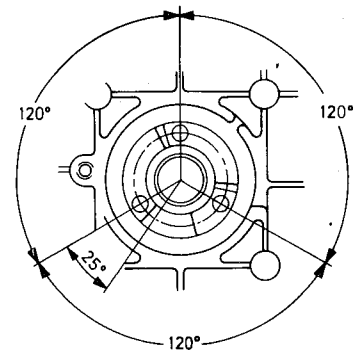
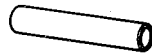

5.6mm (0.220")
PRECISELY FROM
TIP OF DRILL



CYLINDRICAL SPACER
LEANING AGAINST
DRILL CHUCK

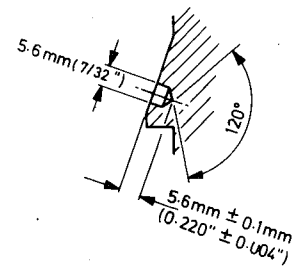

V5976/1

Fig 1 - GA drawing showing detail of modification to cover clutch

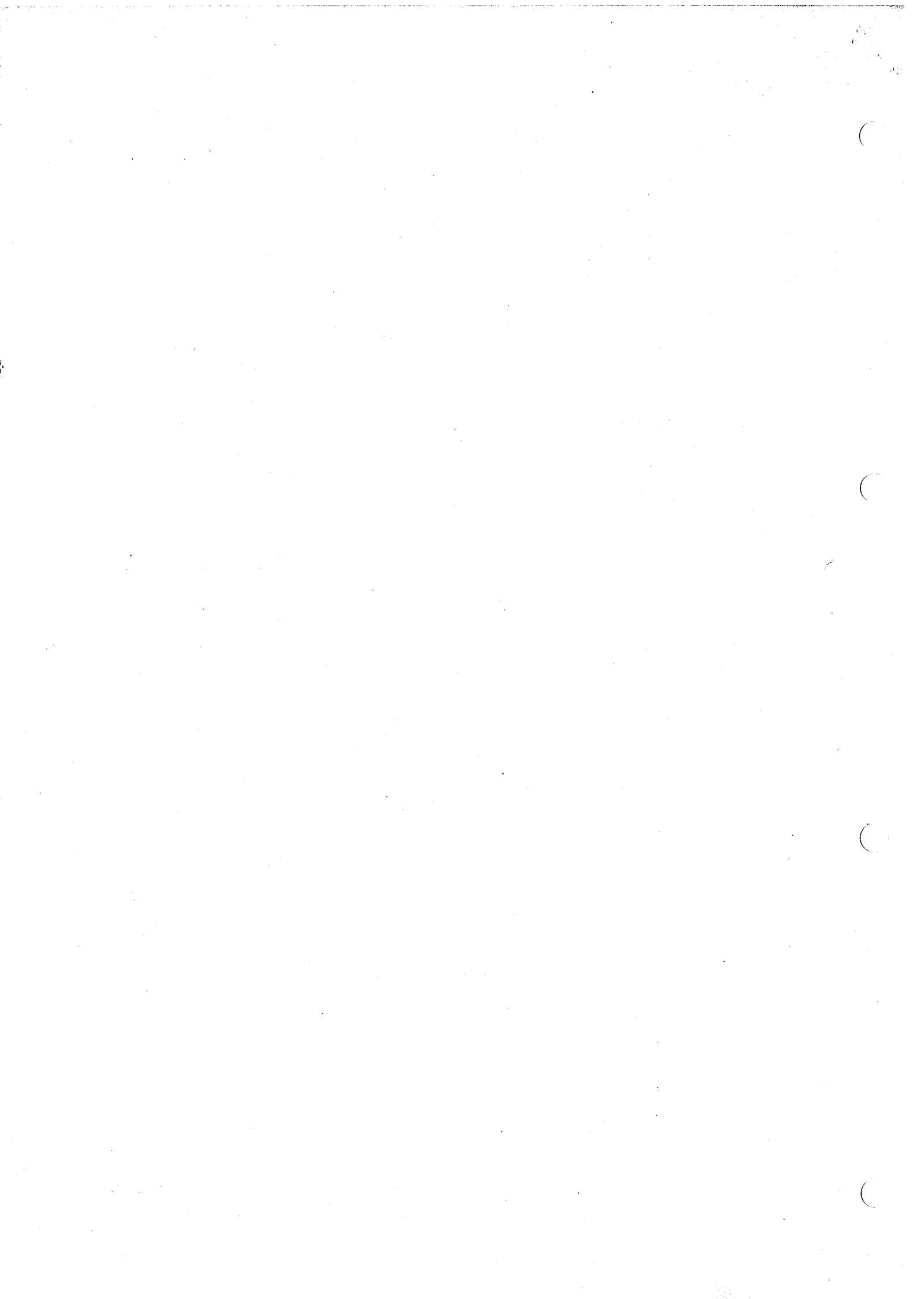

MOTOR CYCLE, LIGHTWEIGHT, 250 cc CAN AM 250

MODIFICATION INSTRUCTION NO 8

Sponsor:
DGEME (A)
File ref: 55706/40
Data Centre Code BVT 7B

Publications Authority:
Vehicles Branch REME
Project No: 70712 (162)

AMENDMENT RECORD

Amdt	Incorporated by	Date	Amdt	Incorporated by	Date
1			4		
2			5		
3			6		

SUBJECT: Canvas pannier bag

(Task 576)

INTRODUCTION

1. This instruction details the fitting of a canvas pannier bag which is issued in lieu of a fibre glass pannier bag now obsolete. On receipt of a canvas pannier bag units are to indent for a carrier, which is to be fitted on to the rack using existing fixings. Canvas pannier bags are to be fitted in pairs, and any serviceable fibre glass pannier bags are to be retained in unit stores and utilised to maintain matched pairs.

1.1 Limitations on use of equipment: Nil.

APPLICABILITY

2. Motor cycle, lightweight, 250 cc Can Am of the following VAC: 1010-0746, 1010-5746 and 1015-0746 all of contract number FVE 22A/36 held by user units.

REASON FOR MODIFICATION

3 Code 5 - to conform to changes in pattern of commercial stores.

PRIORITY

4 ARMY: Routine
RAF: Class 3

ESTIMATED TIME REQUIRED

5 Embodiment: 1 man-hour

MODIFICATION IMPLEMENTATION PLAN

6

6.1 This modification is to be implemented by:

ARMY - Units authorized to carry out levels 2, 3 and 4 maintenance.

RAF - Units on receipt of a canvas pannier bag.

6.2 Associated modification instructions: Nil.

6.3 Modification plate strike action: NA.

Action required by:

7

7.1 Units and establishments holding equipment

7.1.1 Examine vehicle documents to see if modification is applicable.

7.1.2 Examine vehicle to see if modification is embodied and where necessary demand the stores required.

7.1.3 ARMY - On receipt of stores, request REME to modify equipment.

7.1.4 ARMY - Record the modification AESP number and Army Modification Code in vehicle documents.

RAF - Record modification details on RAF Form 4870.

7.2 Army units authorized to carry out levels 2, 3 and 4 maintenance, and RAF units

7.2.1 ARMY - When requested by users or during overhaul, obtain the items listed in para 8 and carry out this modification.

RAF - On receipt of stores, embody the modification.

7.2.2 Record completion details of modification against appropriate entry in equipment documents.

7.2.3. Complete AF G1084A when reporting completion of the modification to Data Centre using the following FORWARD codes:

ARMY: EQUIPMENT CODE: See para 2

MODIFICATION CODE: X 00417

RAF: MODIFICATION CODE: AFK 017

7.3 All recipients of this instruction. Add particulars to AESP ref 2340-K-201-811 Mod Instr Index.

Stores, tools and equipment

8

8.1 Stores to be demanded

Note ...

On receipt of a canvas pannier bag only.

8.1.1 The following item is to be demanded quoting this instruction as authority for demand, and

8.1.2 Registration number of vehicle held by user units.

<u>Item No</u>	<u>COSA Section</u>	<u>NSN/Part No</u>	<u>Designation</u>	<u>Qty per veh</u>
1	LV7BDR	2510-99-838-3662	Carrier pannier bag Manufacturers Part No 744-066-001	2

8.2 Stores to be removed and reduced to scrap

Note ...

Undamaged fibre glass pannier bags are to be retained in unit stores.

2			Fibre glass pannier bag Manufacturers Part No 744-064-000	2
---	--	--	---	---

Sequence of operations

9 Carry out the modification as follows:

Note ...

The item numbers of para 8 are used as references throughout this instruction.

9.1 Remove and discard unserviceable fibre glass pannier bag (item 2). Retain fixings and serviceable fibre glass pannier bag.

9.2 Fit carrier (item 1) to rack as detailed in Fig 1 using retained fixings.

9.3 Fit canvas pannier bag to carrier (item 1) using attached straps of canvas pannier bag.

Testing after embodiment

10 Nil.

EFFECT ON WEIGHT

11 Negligible.

PUBLICATION AMENDMENTS

12 The relevant publication will be amended in due course.

V6107/1

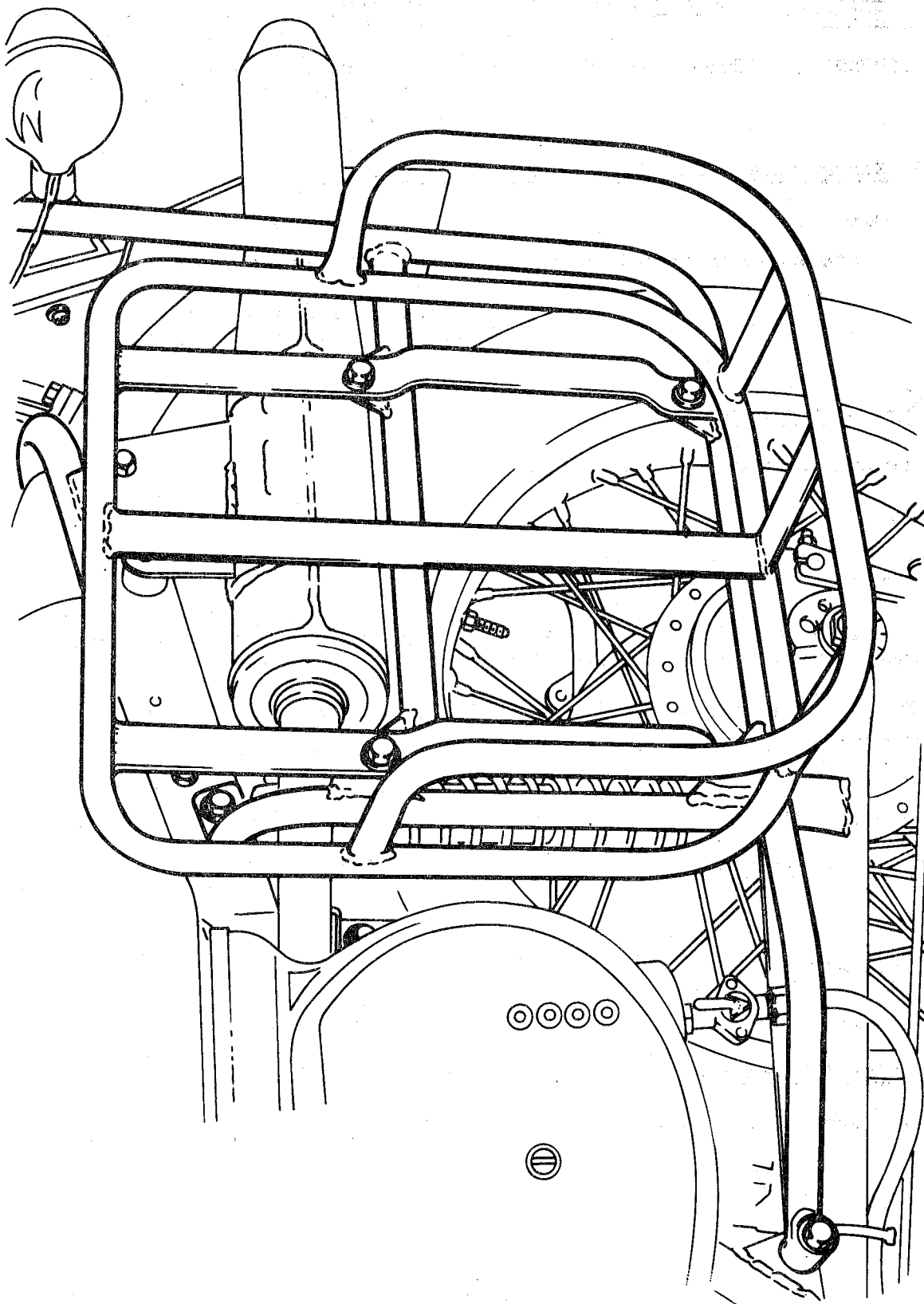

Fig 1 - Carrier canvas pannier bag

MOTOR CYCLE LIGHTWEIGHT 250 cc CAN AM 250

MODIFICATION INSTRUCTION NO 9

Sponsor:
DGEME(A)
File ref: 55706/39
Data Centre Code BVT7B

Publications Authority:
Vehicles & Weapons Branch REME
Project No: 70812(155)

AMENDMENT RECORD

Amdt	Incorporated by	Date	Amdt	Incorporated by	Date
1			4		
2			5		
3			6		

SUBJECT: Improved breather alternator housing and gearbox
(Task 557)

INTRODUCTION

1 This instruction introduces a 'T' piece and air vent as an improvement to the existing breather pipe arrangement of the alternator housing and gearbox to prevent the ingress of water.

1.1 Limitations on use of equipment. Nil.

APPLICABILITY

2 Motor cycle, lightweight, 250 cc Can Am of the following VAC: 1010-0746, 1010-5746 and 1015-0746 all of contract number FVE 22A/36.

2.1 Held by user units.

2.2 Unmodified stock, held in RAOC stores.

REASON FOR MODIFICATION

3 Code 3 - to improve reliability

PRIORITY

4 ARMY: Routine
RAF: Class 3

ESTIMATED TIME REQUIRED

5 Embodiment: 1/2 man-hour

MODIFICATION IMPLEMENTATION PLAN

6

6.1 This modification is to be implemented by:

- ARMY - Units authorized to carry out levels 2, 3 and 4 maintenance.
- RAF - Units not later than the next scheduled servicing and Vehicle Depots before issue of vehicle.

6.2 Associated modification instructions. Nil.

6.3 Modification plate strike action. NA.

Action required by:

7

7.1 Units and establishments holding equipment

7.1.1 Examine vehicle documents to see if modification is applicable.

7.1.2 Examine vehicle to see if modification is embodied and where where necessary demand the stores required.

7.1.3 ARMY - On receipt of stores, request REME to modify equipment.

7.1.4 ARMY - Record the modification AESP number and Army Modification Code in vehicle documents.

RAF - Record modification details on RAF Form 4870 and AF G1084A.

7.2 Army units authorized to carry out levels 2, 3 and 4 maintenance and RAF units

7.2.1 ARMY - When requested by users or during overhaul, obtain the items listed in para 8 and carry out this modification.

RAF - On receipt of stores, embody the modification.

7.2.2 Record completion details of modification against appropriate entry in vehicle documents.

7.2.3 Complete AF G1084A when reporting completion of the modification to Data Centre using the following FORWARD codes:

ARMY - EQUIPMENT CODE:	See para 2
MODIFICATION CODE:	X 00539
RAF - MODIFICATION CODE:	A F K 018

7.3 All recipients of this instruction, add particulars to AESP ref 2340-K-201-811 Mod Instr Index.

Stores, tools and equipment

8

8.1 Stores to be demanded

8.1.1 The following items are to be demanded quoting this instruction as authority for demand, and

8.1.2 Registration number of vehicle held by user units.

8.1.3 Registration number of vehicle for unmodified stock held in RAOC.

<u>Item No</u>	<u>COSA Section</u>	<u>NSN/Part No</u>	<u>Designation</u>	<u>Qty per veh</u>
1	7BDR	4730-21-881-3484	'T' piece	1
2	7BDR	2540-21-881-6600	Air vent	1

Sequence of operations

9 Carry out the modification as follows:

Note ...

The item numbers of para 8 are used as references throughout this instruction.

9.1 With the leg of the 'T' piece (item 1) pointing upwards fit to existing air vent pipes from alternator housing and gearbox.

9.2 Fit air vent (item 2) to 'T' piece and secure as necessary.

Testing after embodiment

10 Nil.

EFFECT ON WEIGHT

11 Negligible.

PUBLICATION AMENDMENTS

12 Nil.

MOTOR CYCLE LIGHT WEIGHT 250 CC CAN AM 250

MODIFICATION INSTRUCTION NO 10

Sponsor:
DGEME(A)

Data Centre Code: BVT 7B

Publications Authority:
Vehs & Wpns Br REME
Project No: 70912 (189)
File ref: VB/55706/43

AMENDMENT RECORD

Amdt	Incorporated by	Date	Amdt	Incorporated by	Date
1			4		
2			5		
3			6		

SUBJECT: Switch, ignition and lighting
(Task No TSS/5203)

INTRODUCTION

1 The existing ignition and lighting switch assy (NSN 7/BDR 2920-99-833-2542) now obsolete has been superseded by switch assy (NSN 7/BDR 2920-99-837-2376). This instruction details the action necessary to fit the new switch.

1.1 Limitations on use of equipment: NIL.

APPLICABILITY

2 Motor cycle, lightweight, 250 cc Can-Am of the following VAC: 1010-0746, 1010-5746 and 1015-0746 held by user units.

REASON FOR MODIFICATION

3 Code 5 - to conform to changes in pattern of commercial stores.

PRIORITY

4 ARMY: Routine) when necessary.
RAF : Class 3)

ESTIMATED TIME REQUIRED

5 Embodiment: 2 man-hours.

MODIFICATION IMPLEMENTATION PLAN

6

6.1 This modification is to be implemented by:

ARMY - Units authorized to carry out levels 2, 3 and 4 maintenance.

RAF - Units.

6.2 Associated modification instructions: Nil.

6.3 Modification plate strike action: NA.

Action required by:

7

7.1 Units and establishments holding equipment

7.1.1 Examine vehicle documents to see if modification is applicable.

7.1.2 Examine vehicle to see if modification is embodied and where necessary demand the stores required.

7.1.3 ARMY - On receipt of stores, request REME to modify equipment.

7.1.4 ARMY - Record the modification Subject, AESP number and Army Modification Code in vehicle documents.

RAF - Record modification details on RAF Form 4870 and AF G1084A.

7.2 Army units authorized to carry out levels 2, 3 and 4 maintenance, and RAF units

7.2.1 ARMY - When requested by users or during overhaul, obtain the items listed in para 8 and carry out this modification.

RAF - On receipt of stores, embody the modification.

7.2.2 Record completion details of modification against appropriate entry in vehicle documents.

7.2.3 Complete AF G1084A when reporting completion of the modification to Data Centre using the following FORWARD codes:

ARMY: EQUIPMENT CODE - See para 2
MODIFICATION CODE X00690

RAF: MODIFICATION CODE AFK 019

7.3 All recipients of this instruction. Add particulars to AESP ref 2340-K-201-811 Mod Instr Index.

Stores, tools and equipment

8

8.1 Stores to be demanded

8.1.1 The following item is to be demanded quoting this instruction as authority for demand; and

8.1.2 Registration number of vehicle for equipment held by user units.

<u>Item No</u>	<u>COSA Section</u>	<u>NSN/Part No</u>	<u>Designation</u>	<u>Qty per eqpt</u>
1	7/BDR	2920-99-837-2376	Switch, ignition and lighting	1
8.2 <u>Stores to be removed and reduced to scrap</u>				
2	7/BDR	2920-99-833-2542	Switch, ignition and lighting	1

Sequence of operations

9 Carry out the modification as follows:

Note ...

The item numbers of Para 8 are used as reference throughout this instruction.

9.1 Unsolder and discard loom and assy bridging straps from the new switch (item 1).

9.2 Disconnect vehicle battery.

9.3 Remove existing switch (item 2) from handlebars of cycle and unsolder attached cables. Disconnect switch.

9.4 Solder cables into new switch in the following sequence:

<u>CABLE COLOUR</u>	<u>SWITCH POSITION NUMBER</u>
GREEN	8
BLACK/WHITE TRACER	3
GREY	7
ORANGE	4
RED	2
BOTH GREEN/WHITE TRACER	1

WARNING ...

POSITION NOS 6 AND 8 ARE IN CLOSE PROXIMITY - DO NOT BRIDGE WHEN RESOLDERING.

Note ...

Switch position numbers 5, 6, 9, 10 and 11 are NOT used.

9.5 Refit switch to handle bars.

9.6 Check that the wiring from the ignition switch and rectifier is connected as follows, rectify if necessary.

9.6.1	<u>WIRING COLOUR</u>	<u>CONNECTOR TYPE</u>	<u>LOCATION</u>
Wiring from ign switch	ORANGE CONNECTED INTO ORANGE BLACK/TRACER	SINGLE	HEADLIGHT CASING
	GREEN WITH ORANGE INSULATION TAPE WRAPPED AROUND CONNECTED INTO THREE ORANGES.	FOUR WAY	HEADLIGHT CASING
9.6.2			
Rectifier	BLUE CONNECTED INTO YELLOW/ BLUE TRACER.	SINGLE	UNDER SEAT
	GREY/VIOLET TRACER CONNECTED INTO 3 ORANGES.	FOUR WAY	UNDER SEAT
	BLACK/YELLOW TRACER CONNECTED TO BLACK/YELLOW TRACER AND TWO(2) YELLOWS.	FOUR WAY	ADJACENT TO BATTERY

Testing after embodiment

10 Carry out a functional test of switch.

EFFECT ON WEIGHT

11 Negligible.

PUBLICATION AMENDMENTS

12 Nil.

MOTOR CYCLE LIGHT WEIGHT 250CC CAN AM 250

MODIFICATION INSTRUCTION NO 11

Sponsor:
DGEME(A)
Data Centre Code: BVT7B

Publications Authority:
Vehs & Wpns Br REME
Project No: 70912 (293)
File ref: 55706/42

AMENDMENT RECORD

Amdt	Incorporated by	Date	Amdt	Incorporated by	Date
1			4		
2			5		
3			6		

SUBJECT: Chain case assembly
No 575/1

INTRODUCTION

1 This instruction refers to the complete enclosure of the rear driving chain assy by introducing a chain case assy to prevent rapid wear of chain and sprocket. To be fitted when considered necessary.

1.1 Limitations on use of equipment. NIL

APPLICABILITY

2 Motor cycle, lightweight 250CC CAN AM of the following (VAC 1010-4100 and 1010-9100) both of contract 22A/88.

2.1 Held by user units.

REASON FOR MODIFICATION

3 Code 3 - to improve reliability

PRIORITY

4 ARMY: Routine
RAF: Class 3

ESTIMATED TIME REQUIRED

5 Embodiment: 1 man-hour

MODIFICATION IMPLEMENTATION PLAN

6

6.1 This modification is to be implemented by:

ARMY - Units authorized to carry out levels 2, 3 and 4 maintenance.

RAF - Units not later than the next routine servicing.

6.2 Associated modification instructions: Nil.

6.3 Modification plate strike action: NA.

Action required by:

7

7.1 Units and establishments holding equipment

7.1.1 Examine vehicle documents to see if modification is applicable.

7.1.2 Examine vehicle to see if modification is embodied and where necessary demand the stores required.

7.1.3 ARMY - On receipt of stores, request REME to modify equipment.

7.1.4 ARMY - Record the modification Subject, AESP number and Army Modification Code in vehicle documents.

RAF - Record modification details on RAF Form 4870 and AF G1084A.

7.2 Army units authorized to carry out levels 2, 3 and 4 maintenance, and RAF units

7.2.1 ARMY - When requested by users or during overhaul, obtain the items listed in para 8 and carry out this modification.

RAF - On receipt of stores, embody the modification.

7.2.2 Record completion details of modification against appropriate entry in vehicle documents.

7.2.3 Complete AF G1084A when reporting completion of the modification to Data Centre using the following FORWARD code:

ARMY: EQUIPMENT CODE - See para 2
MODIFICATION CODE X00755

RAF: MODIFICATION CODE AFK 020

7.3 All recipients of this instruction. Add particulars to AESP 2340-K-201-811 Mod Instr Index.

Stores, tools and equipment

8

8.1 Stores to be demanded

8.1.1 The following modification set is to be demanded quoting this instruction as authority for demand and,

8.1.2 Registration number of vehicle for equipment held by user units.

<u>Item No</u>	<u>COSA Section</u>	<u>NSN/Part No</u>	<u>Designation</u>	<u>Qty per eqpt</u>
A	7 BDR	2530-99-839-4192	Mod set: Chain case assy	1
			comprising:	
1			Chain case, upper	(1)
2			Chain case, lower	(1)
3			Wheel spacer/plate	(1)
4			Plug, rubber, inspection, 25mm dia	(1)
5			Shield, front sprocket, plastic	(1)
6			Washer 6mm id x 20mm cd	(5)
7			Bolt, socket hd 6mm dia x 16mm lg	(3)
8			Bolt, socket hd, 6mm dia x 50mm lg	(2)
9			Nut, nyloc 6mm	(1)

8.2 Stores to be removed and reduced to scrap

10	7 BDR	5365-21-879-9081	Spacer rh rear wheel	1
11	7 BDR	2540-33-837-5341	Guard, chain	1

Sequence of operations

9 Carry out the modification as follows:

Note ...

The item numbers of para 8 are used as reference throughout this instruction.

9.1 Place cycle on centre stand.

9.2 Remove and discard the existing chain guard (item 11).

Note ...

The front bolt may have to be "persuaded" out.

9.3 Remove and retain large wheel nut and snail cam from rear wheel spindle. With the aid of an assistant pushing down on front of the machine the rear wheel should be raised and the rear spindle removed. Drop the wheel a few inches until the wheel spacer (item 10) on the drive side can be removed. Replace the spacer with the new spacer/plate (item 3). Refit wheel, spindle, snail cam and wheel nut. The rear wheel can now be set back on the ground.

9.4 Adjust chain tension and check that cams are equally set. Half tighten the wheel nut with spacer/plate (item 3) in the vertical position.

Note ...

It should not be necessary to remove the chain or slacken the brake rod or anchor arm at any stage.

9.5 Carefully slide the chain case upper (item 1) into position ensuring that the rectangular cut-out half-way along the lower edge fits over a gusset on the swinging arm and that the oval hole (approx. 10mm x 20mm) on the inside at the front is fitted over a bolt aligning tube welded to the top of the swinging arm. The chain case half will have to be prised slightly apart by hand from underneath to fit over this tube. The upper half should now fit snugly into place with the mounting holes at front and rear lining up. Fit top rear mounting bolt and washer (item 6 and 7).

9.6 Pull side stand down to half way position. Offer up the lower half of chain case (item 2) easing the rubber sheet around the sidestand lug and loosely fit the two rear mounting bolts and washers (items 6 and 7).

9.7 At the front inside edge there is a steel strip rivetted to the case. This strip should be fitted outside the upper case and should line up with the front mounting bolt tube. Fit bolt (item 8) from left hand side of chain case through metal strip and mounting tube to emerge on the outside of the swinging arm. Secure bolt with washer and nyloc nut (item 6 and 9).

9.8 Tighten remaining fixing bolts and spin rear wheel to check clearance. If contact is made at the rear, bend spacer/plate (item 3) as necessary. Fully tighten the wheel nut.

Note ...

When adjusting the chain remember to slacken the front nyloc nut slightly to allow "case" to move.

9.9 To cover the gap below gearbox sprocket, fit plastic shield (item 5) to crankcase with bolt and washer (item 6 and 8) using vacant tapped hole below sprocket.

Note ...

As there is only one mounting point for the plastic shield, a spring (not detailed in stores list) is provided to hold the shield in tension. The securing bolt (item 8) may need to be shortened slightly.

Testing after embodiment

10 Nil

EFFECT ON WEIGHT

11 Negligible

PUBLICATION AMENDMENTS

12 Nil

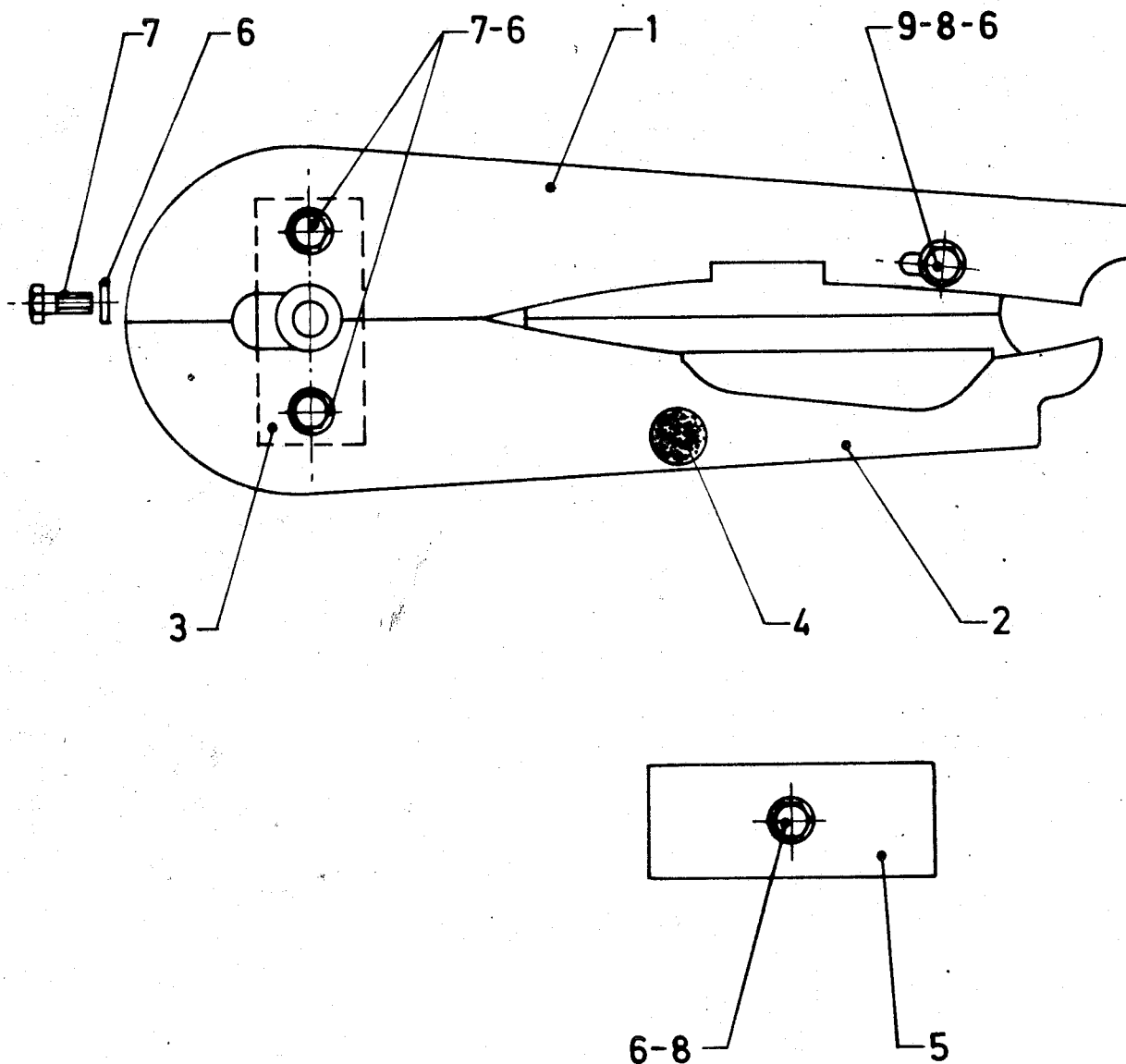

Fig 1 Chain Case

V 6904/1